

IT3-40mm SI Report

Three-Piece Mezzanine Connector for 20+ Gbps Applications

December 9, 2009



HIROSE ELECTRIC

Outline

- HFSS simulation models for connector and via
- Insertion and return losses, NEXT, FEXT, and impedance profile
- Insertion loss to crosstalk ratio (ICR)
 - Fully populated vs. 50% density
 - Connector-only vs. full channel
- Eye diagrams
- Summary
- Appendix
 - Measurement vs. simulation correlation
 - Measured ICR for IT3-40mm

HFSS simulation model

- A .s60p file was created, and the differential pair's response was examined.

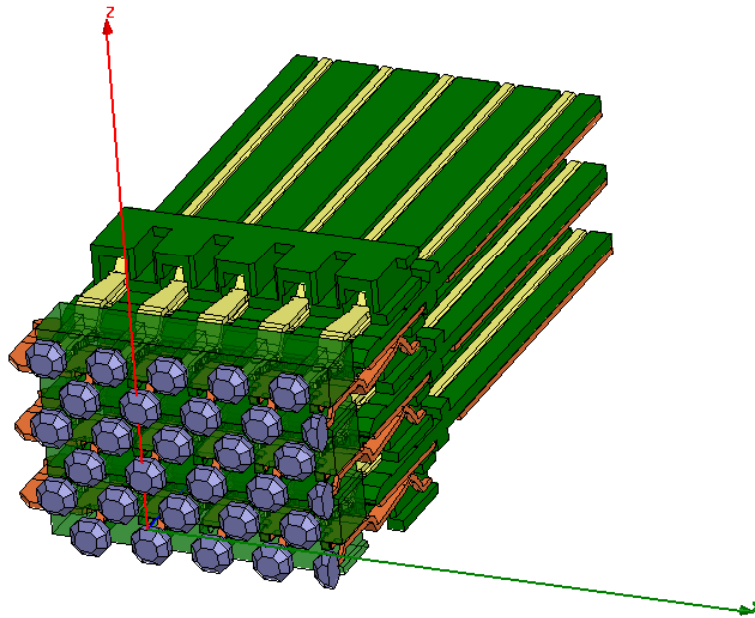

Simulation model for IT3-40mm
(only a quadrant of the model is shown)

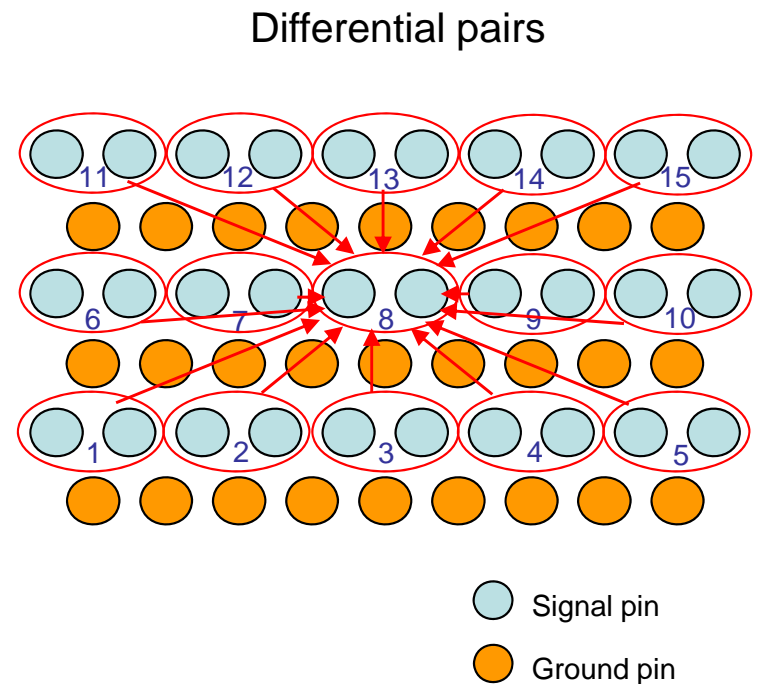

Via model

- A .s60p Touchstone file was also created to study the effect of via stub and coupling.

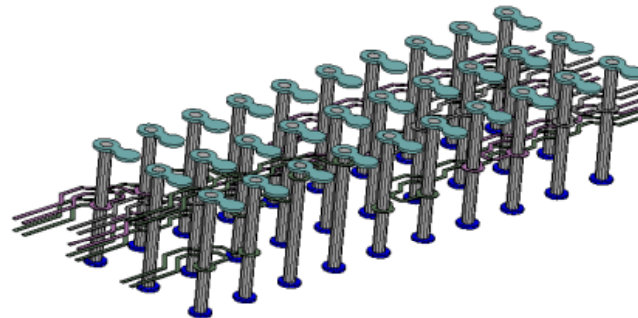
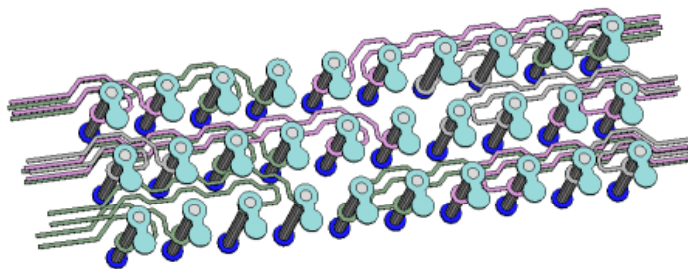
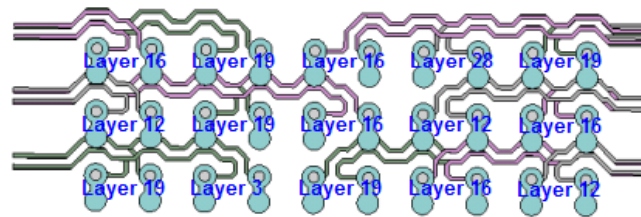

Layer No.			Mil
		Solder mask	0.5
1	TOP		2.84
		Pre-preg	4.5
2	Ground		0.7
		Core	3
3	Sig 1		0.7
		Pre-preg	3.5
4	Sig 2		0.7
		Core	3
5	Ground		0.7
		Pre-preg	3.5
6	Ground		0.7
		Core	3
7	Sig 3		0.7
		Pre-preg	3.5
8	Sig 4		0.7
		Core	3
9	Ground		0.7
		Pre-preg	3.5
10	Ground		0.7
		Core	3
11	Sig 5		0.7
		Pre-preg	3.5
12	Sig 6		0.7
		Core	3
13	Ground		0.7
		Pre-preg	3.5
14	Ground		0.7
		Core	3
15	Sig 7		0.7
		Pre-preg	3.5
16	Sig 8		0.7
		Core	3
17	Ground		0.7
		Pre-preg	3.5
18	Ground		0.7
		Core	3
19	Sig 9		0.7
		Pre-preg	3.5
20	Sig10		0.7
		Core	3
21	Ground		0.7
		Pre-preg	3.5
22	Ground		0.7
		Core	3
23	Sig11		0.7
		Pre-preg	3.5
24	Sig12		0.7
		Core	3
25	Ground		0.7
		Pre-preg	3.5
26	Ground		0.7
		Core	3
27	Sig13		0.7
		Pre-preg	3.5
28	Sig14		0.7
		Core	3
29	Ground		0.7
		Pre-preg	4.5
30	BOTTOM		2.84
		Solder mask	0.5
		Total thickness (mil)	121.78

IEEE 802.3ap channel spec.

- IEEE 802.3ap defines the channel spec. of insertion-loss-to-crosstalk ratio (ICR) up to 5 GHz for 10 Gbps data rate. We will extrapolate this ICR curve to 10 GHz for 20 Gbps data rate.

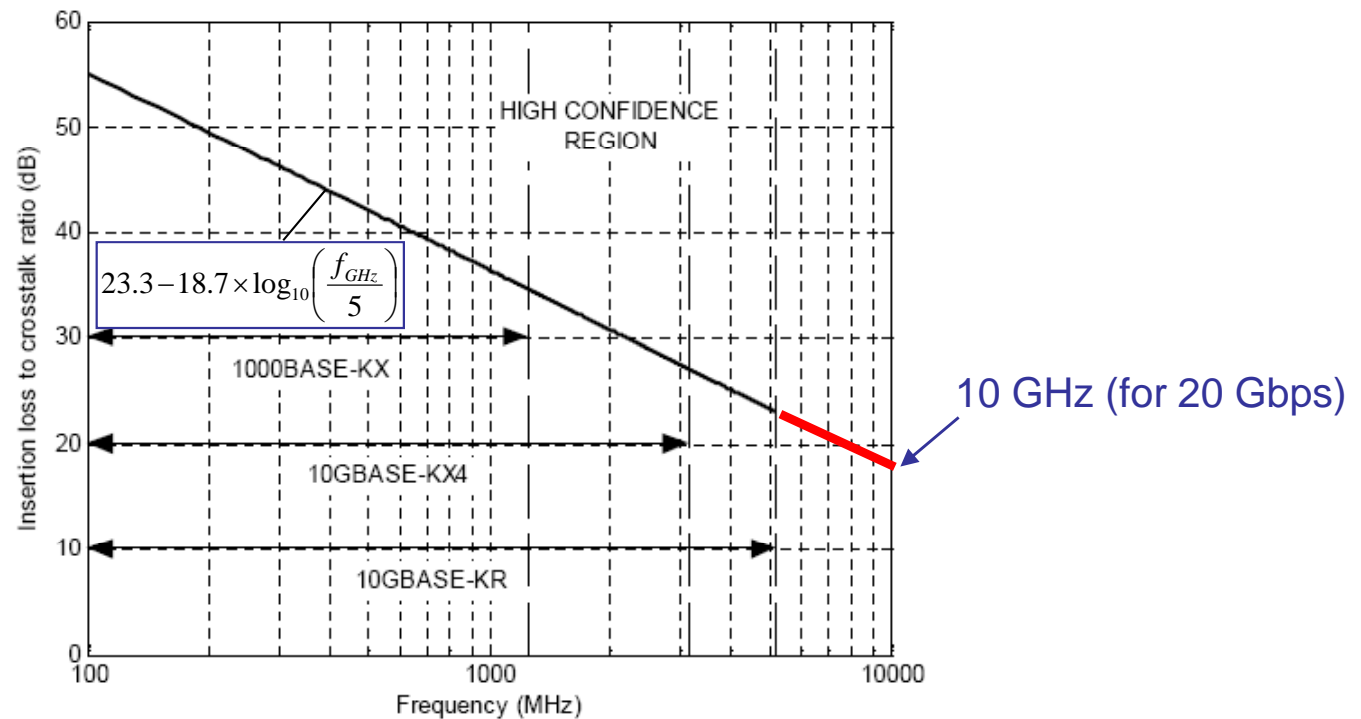
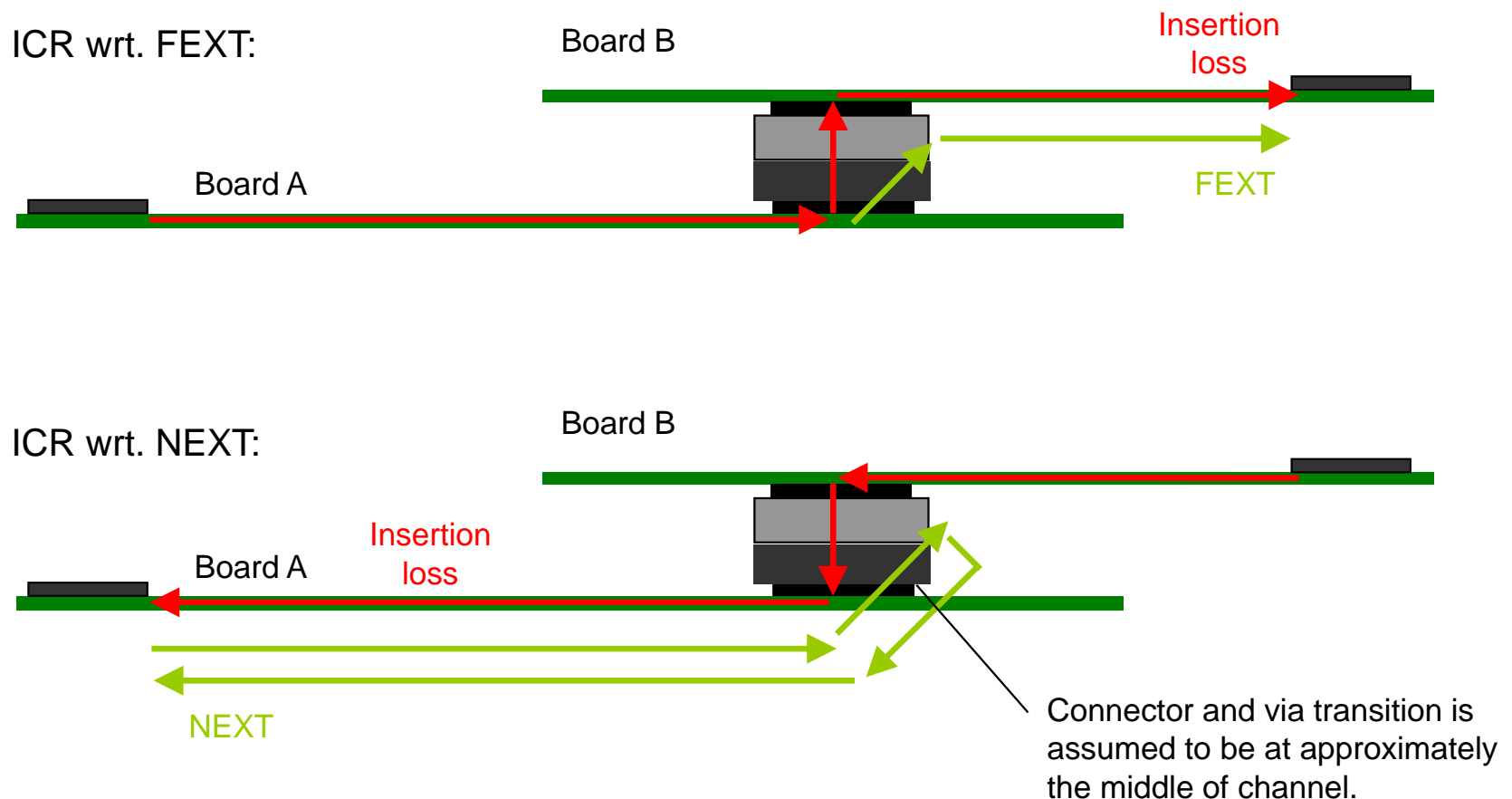

Figure 69B-8—Insertion loss to crosstalk ratio limit

Connector's ICR

- The connector and via transition's contribution to ICR is independent of channel length, because the insertion loss and crosstalk attenuate at the same rate.



IT3-40mm connector-only response (Fully populated)

- All insertion and return losses, and NEXT and FEXT are shown for the center pair.

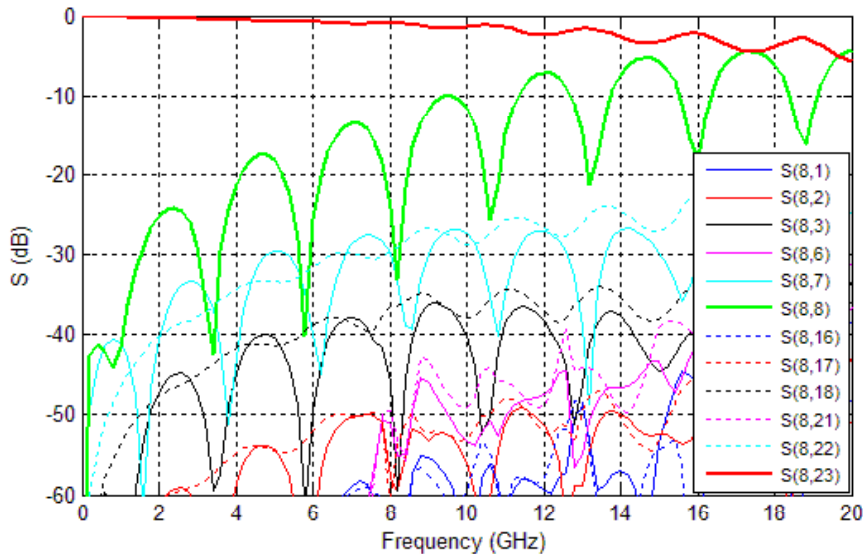
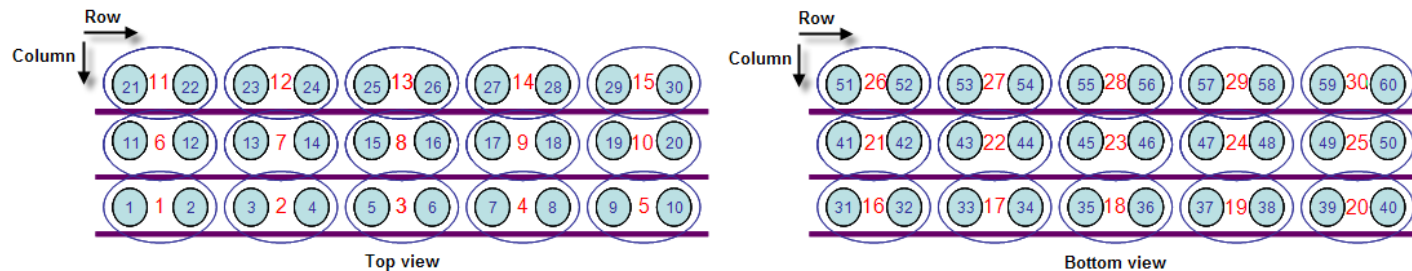

IT3-40mm Differential Impedance (Ohm)			IT3-40mm Differential Delay (ps)		
Column			Column		
N	2 to N-1	1	N	2 to N-1	1
99.95	99.83	101.13	229.50	229.59	230.12
99.17	99.19	100.31	228.46	228.45	228.99
99.35	99.37	100.58	228.22	228.20	228.56
99.17	99.19	100.31	228.46	228.45	228.99
99.95	99.83	101.13	229.50	229.59	230.12

Impedance and delay @1 GHz

IT3-40mm connector-only response (60% density)

- Both NEXT and FEXT are reduced, if some pins are skipped (i.e., terminated or assigned to low-speed signals).

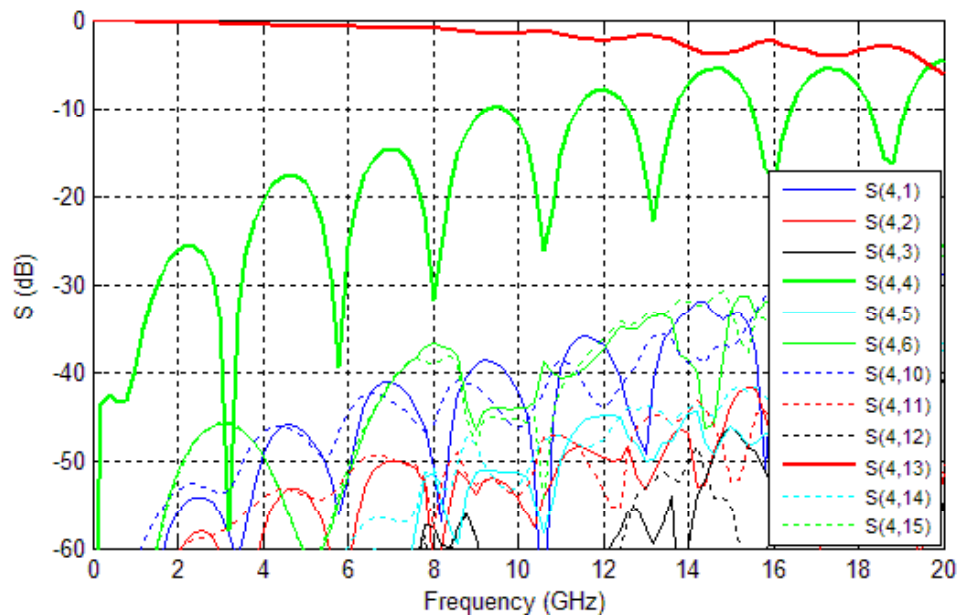
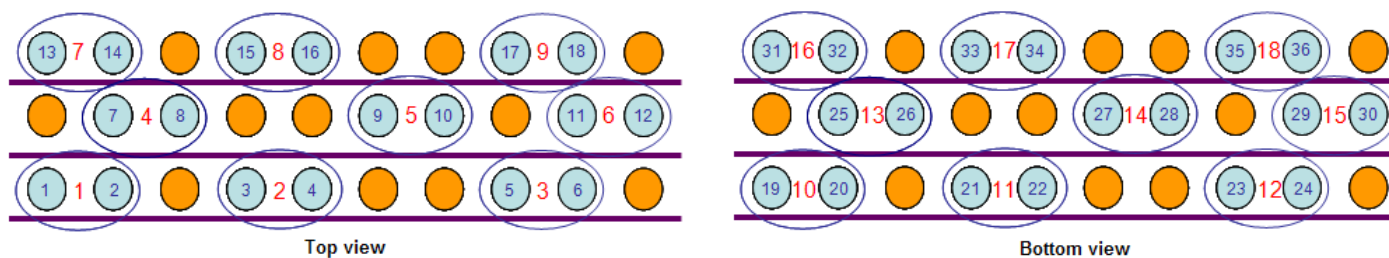

IT3-40mm connector-only response (50% density)

- We observe even less NEXT and FEXT with 50% density.

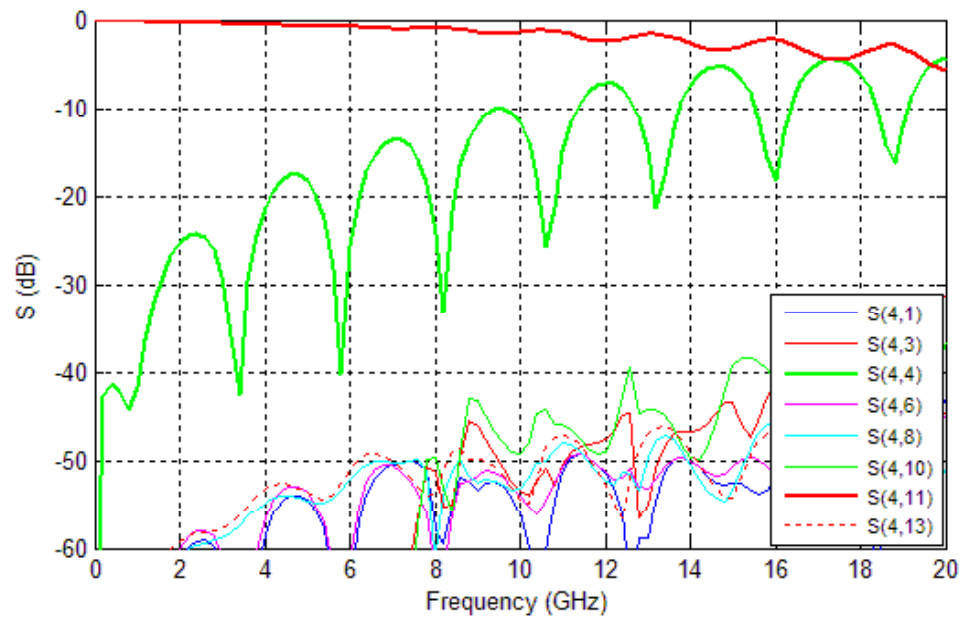
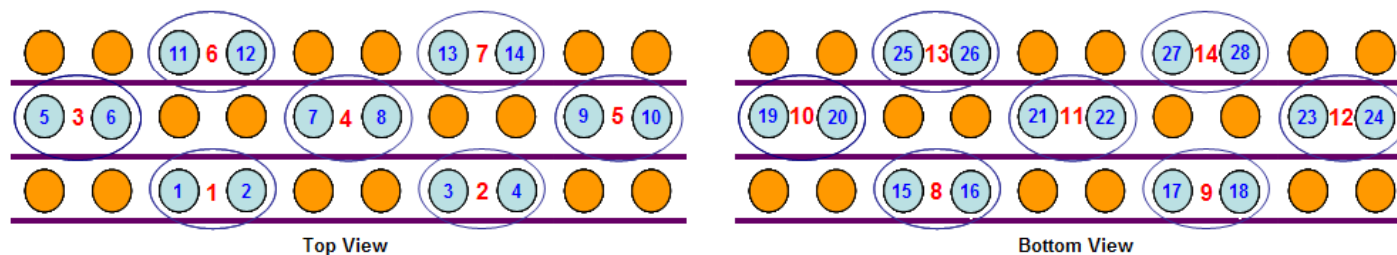

Impedance at 60ps and 30ps rise time (20%~80%)

- IT3's receptacles were designed to have slightly high impedance to offset the via's and via stub's low impedance.

Connector only

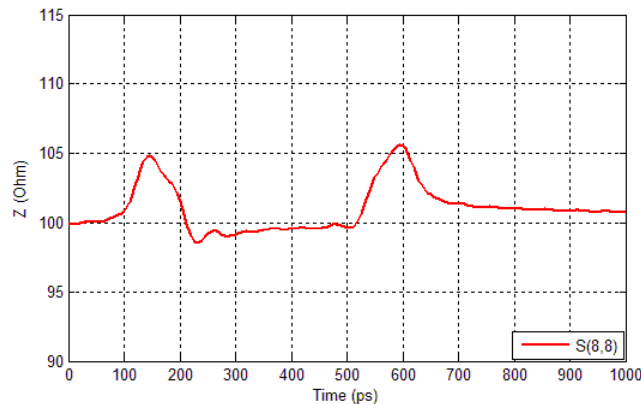

60ps rise time (20%-80%) and 5.25GHz bandwidth

Connector + ~60mil via stubs

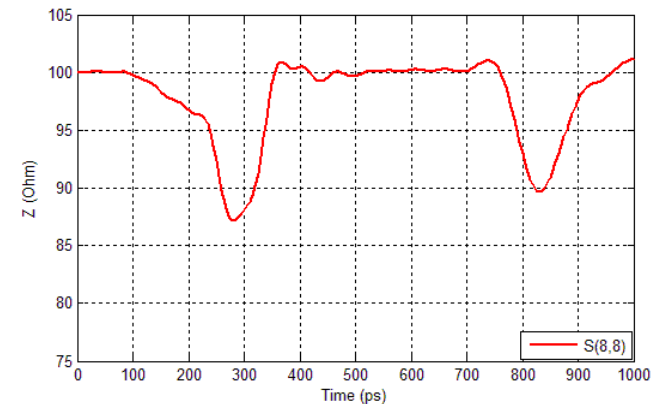

60ps rise time (20%-80%) and 5.25GHz bandwidth

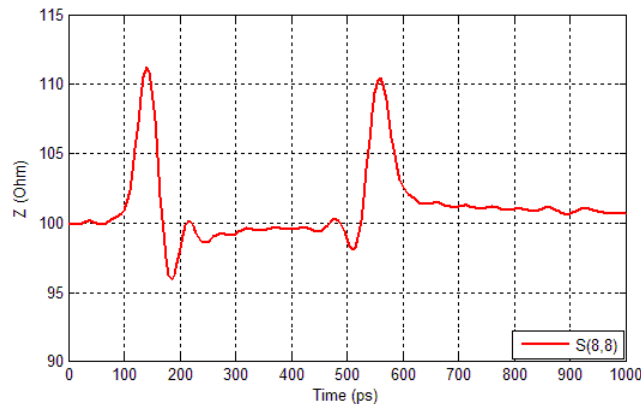

30ps rise time (20%-80%) and 10.5GHz bandwidth

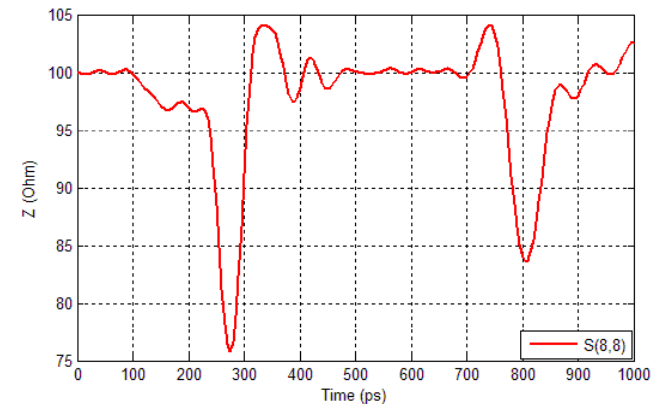

30ps rise time (20%-80%) and 10.5GHz bandwidth

ICR in a full channel (Fully populated)

- ICR with 14-aggressor connector and via FEXT, and ~60 mil stub meets the extrapolated IEEE 802.3ap spec. for 20 Gbps.

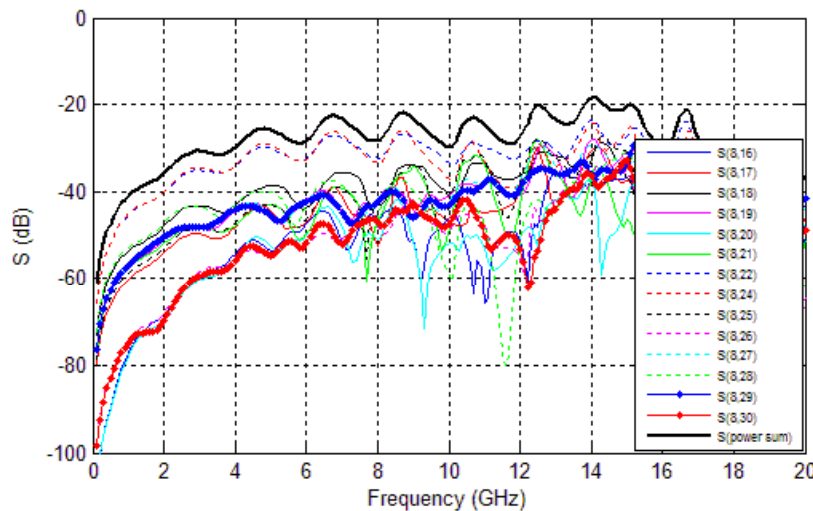
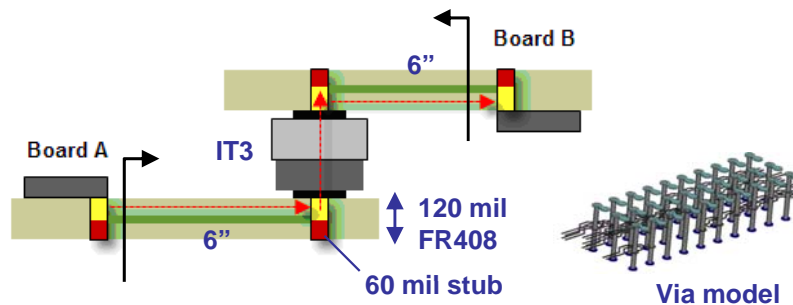

FEXT for via-connector-via
(w/o trace attenuation)

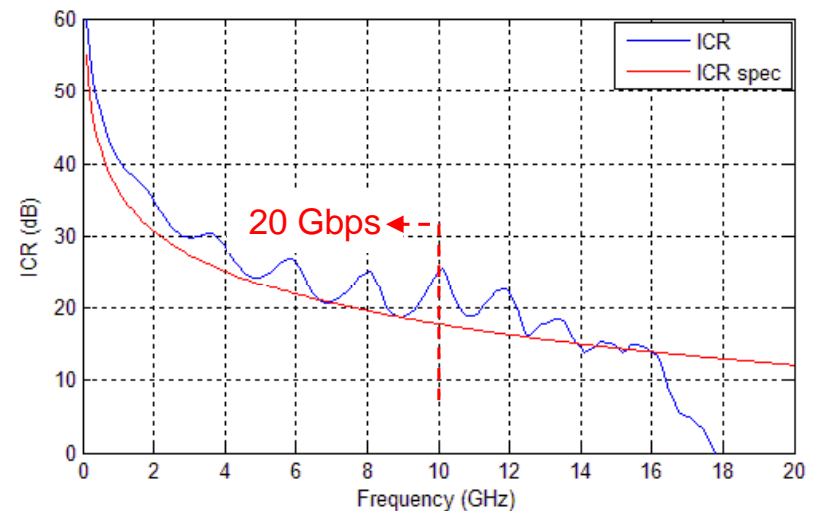

ICR with 14 FEXTs

ICR in a full channel (50% density)

- ICR with 6-aggressor connector and via FEXT, and ~60 mil stub gives plenty of margin @20 Gbps, as compared to the extrapolated IEEE 802.3ap spec.

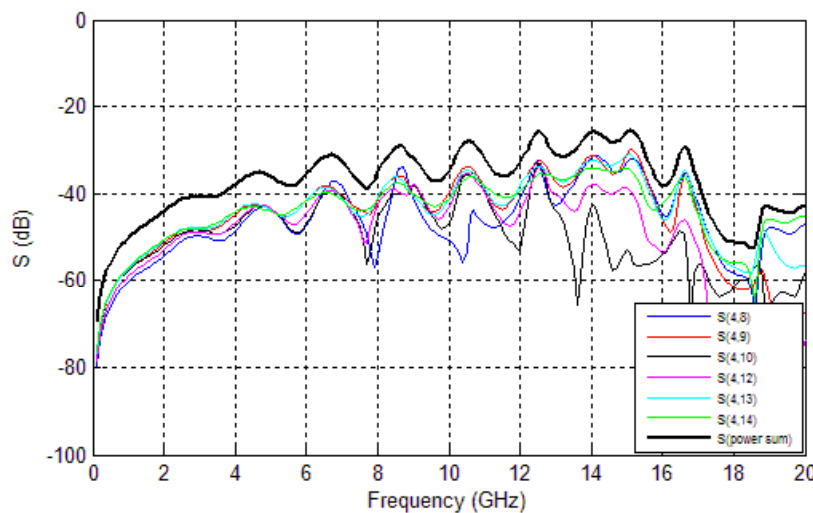
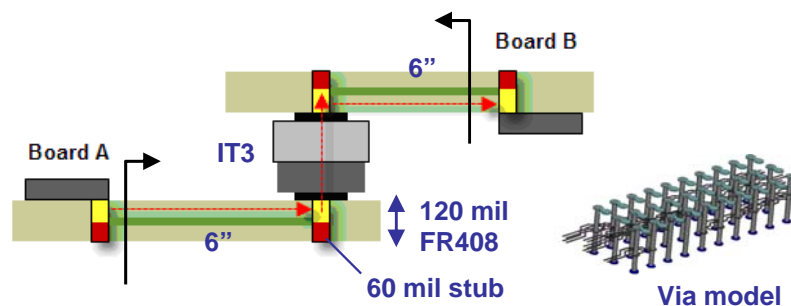

FEXT for via-connector-via
(w/o trace attenuation)

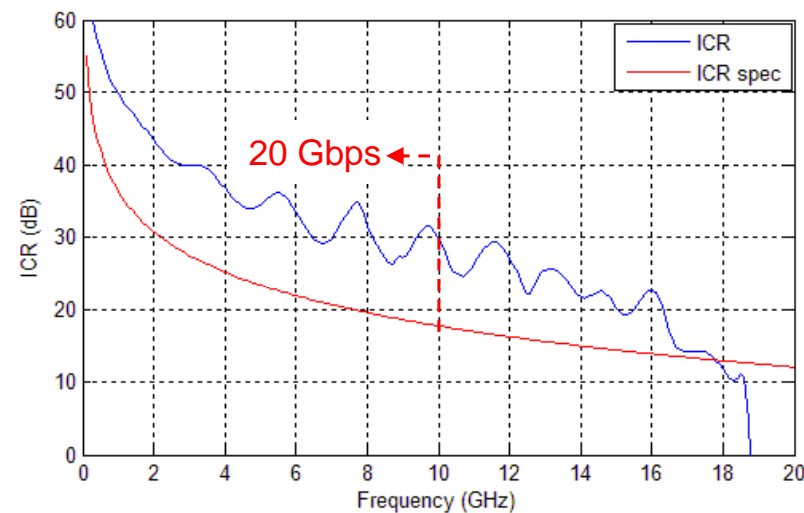

ICR with 6 FEXTs

Channel simulation @6.25 Gbps (Fully populated)

- ADS simulation with 3-tap TX equalization gives good open eyes @6.25 Gbps with ~60mil via stub and 14 FEXT included.

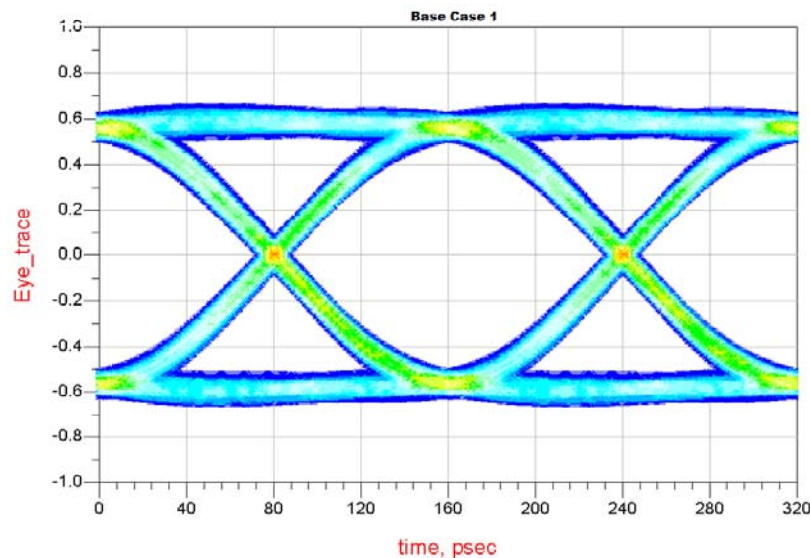
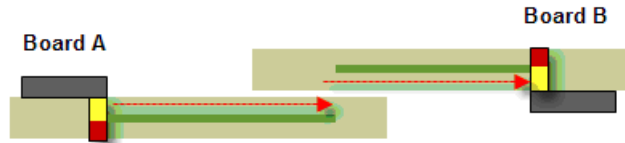

Without connector
Jitter = 11.64ps
Eye Height = 1024.59mV

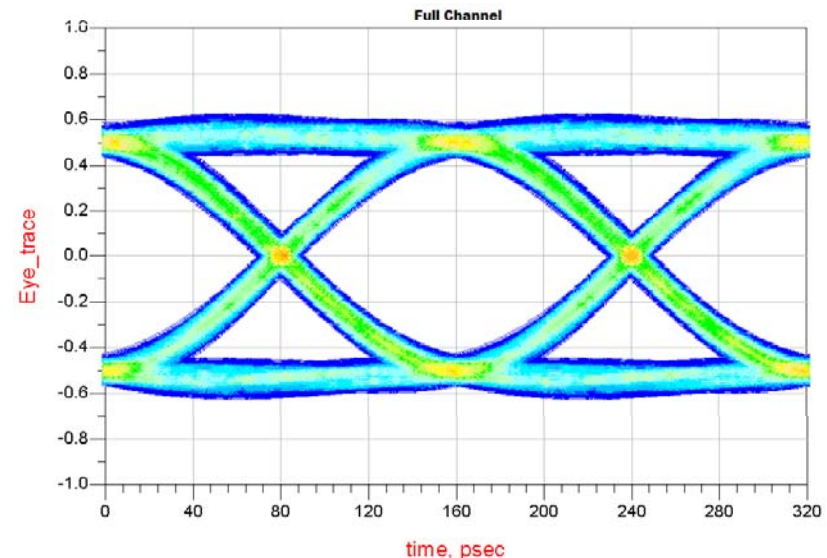
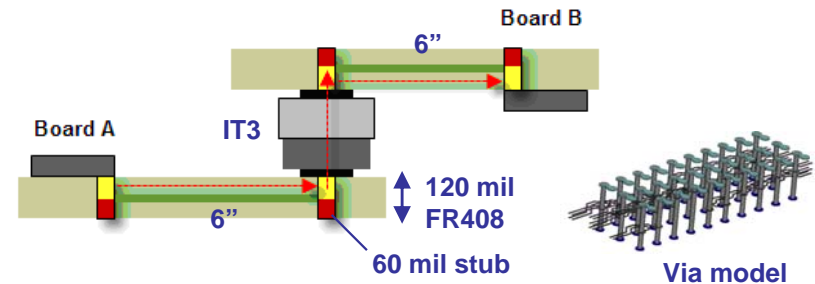

With connector and 14 FEXT
Jitter = 15.78ps
Eye Height = 892.83mV

Channel simulation @12.5 Gbps (50% density)

- ADS simulation with 3-tap TX equalization gives good open eyes @12.5 Gbps with ~60mil via stub and 6 FEXT included.

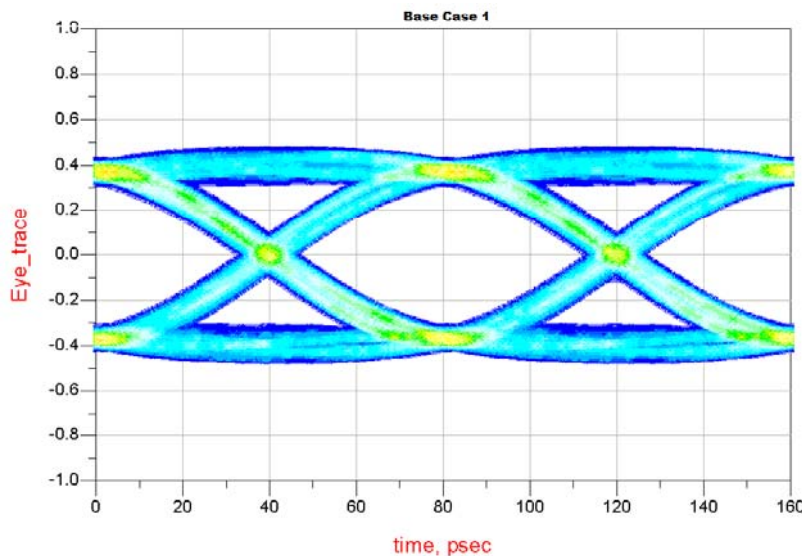
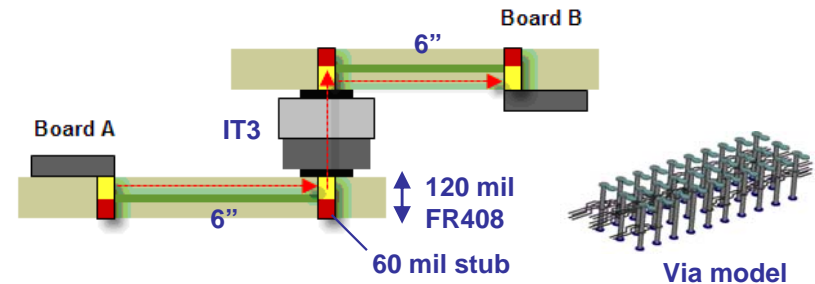
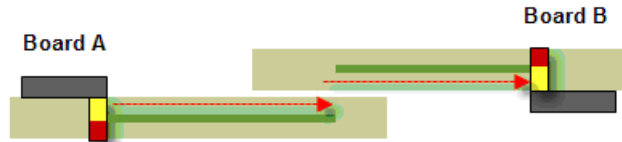

Without connector
Jitter = 13.84ps
Eye Height = 559.63mV

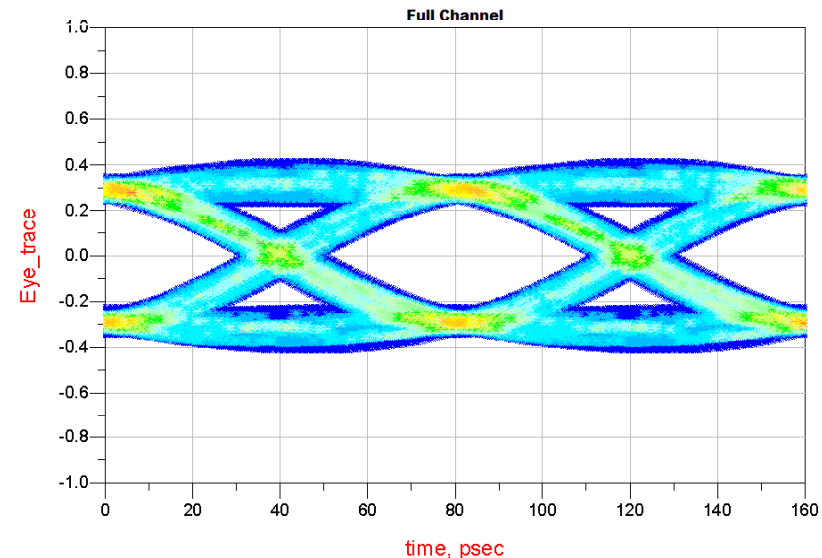

With connector and 6 FEXT
Jitter = 17.42ps
Eye Height = 476.41mV

Channel simulation @20 Gbps (50% density)

- ADS simulation with 7-tap TX equalization gives good open eyes @20 Gbps with ~60mil via stub and 6 FEXT included.

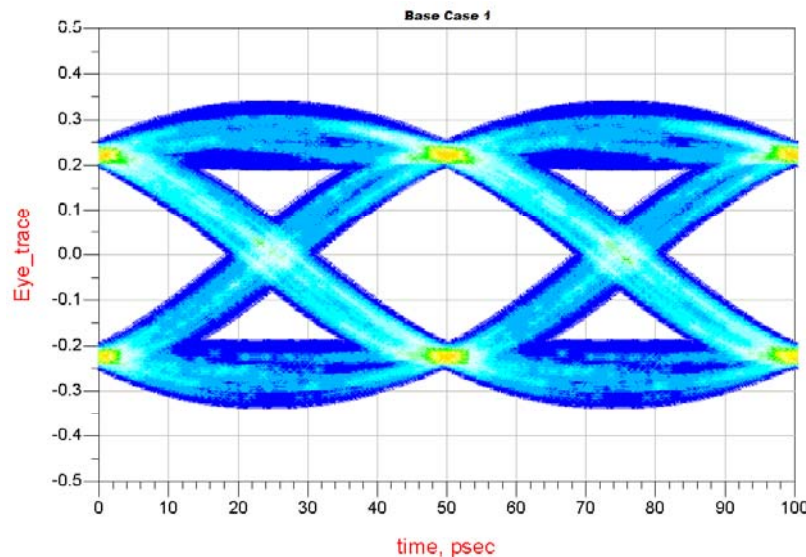
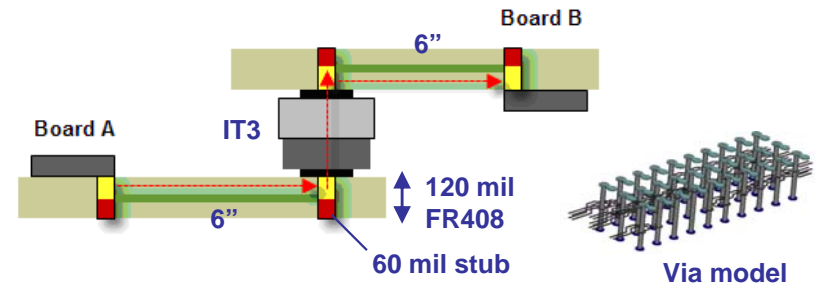
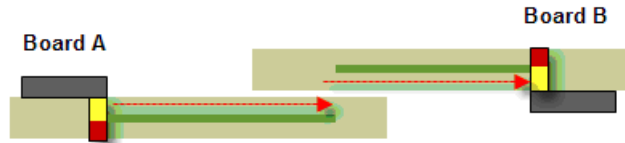

Without connector

Jitter = 15.91ps

Eye Height = 296.02mV

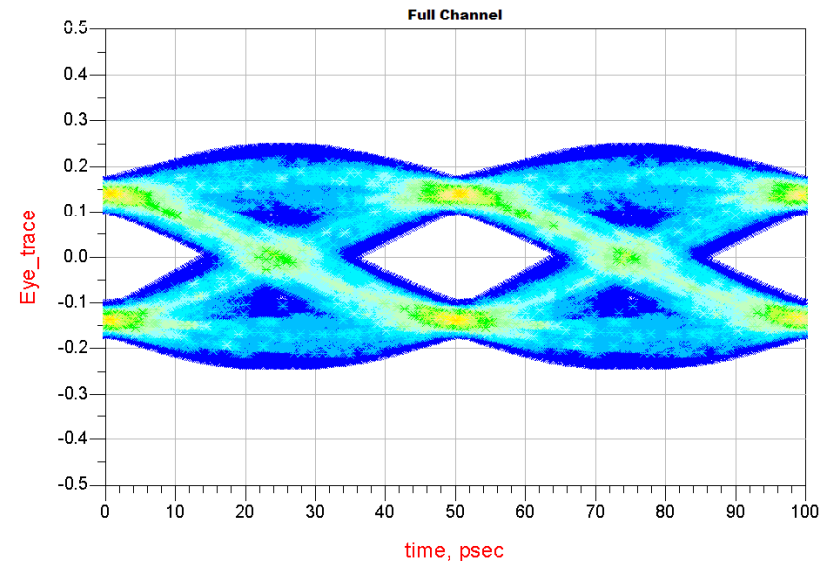

With connector and 6 FEXT

Jitter = 20.64ps*

Eye Height = 206.91mV*

*Degradation is mainly due to via stubs.

Summary

- IT3 meets the extrapolated IEEE802.3ap's ICR spec. for 20+ Gbps.
- Both characterization and demo boards are available for evaluation.

