PCB Routing Guideline

FX10 Series Mezzanine Connector

Version 1.2

November 17, 2010

10HSI-S075-R0-CHT



HIROSE ELECTRIC (U.S.A.), INC.
20400 STEVENS CREEK BLVD., SUITE 250
SAN JOSE, CA 95014
PHONE: 408-253-9640, FAX: 408-253-9641

Table of Contents

1. Overview	4
2. Layout/design requirements	5
2.1 Connector land pattern/ pin assignment	5
2.2 Ground plane with and without cutouts.....	6
2.3 Recommended ground via locations.....	7
2.4 Routing suggestions / examples	8
3. Current rating	12

Revision History

Name	Date	Reason For Changes	Version
Jeremy Buan	12-21-09	First created	1.0
Jeremy Buan	01-27-10	Updated FX10 header and receptacle pictures Modified FX10 header land pattern Added differential via example	1.1
Fernando Cheng	11-17-10	Updated Section 2.2 Added via footprint without ground cutout Updated Section 2.4 Added routing suggestion and via locations	1.2

1. Overview

Hirose's FX10 connector is designed to provide high-speed differential connections between two parallel boards. Figure 1 and Figure 2 show the FX10 receptacle and FX10 header, respectively. Careful pin assignment, footprint design and layout will ensure that the high-speed signals can be transmitted from board to board successfully.



Figure 1 FX10 receptacle



Figure 2 FX10 header

2. Layout/design requirements

2.1 Connector land pattern/ pin assignment

Figure 3 shows the recommended PCB land pattern for the FX10 receptacle with 168 signal contacts. Figure 4 shows the recommended PCB land pattern for the FX10 header with 168 signal contacts.

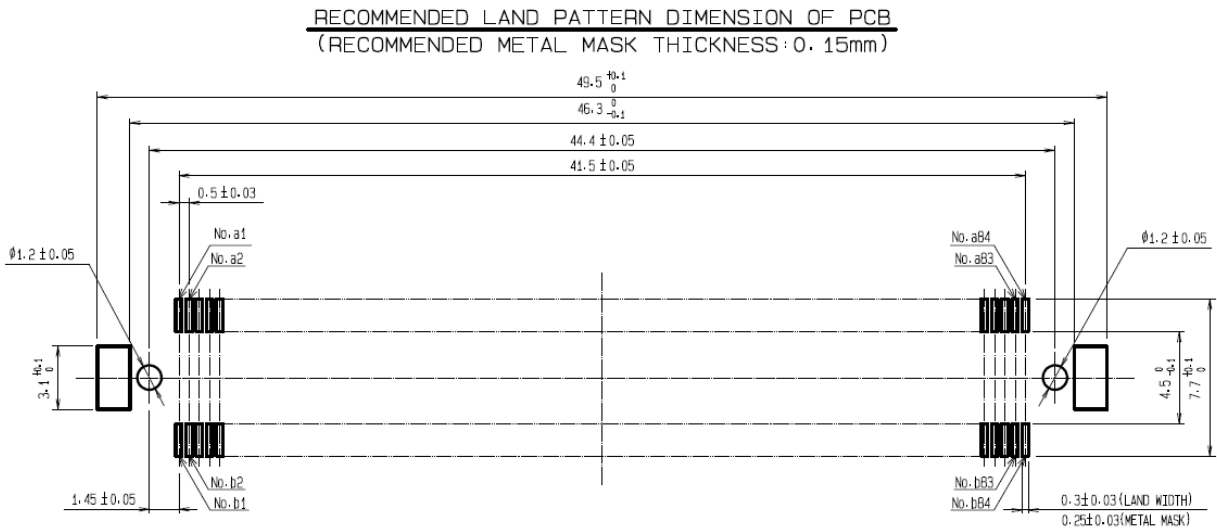

Figure 3 FX10 receptacle land pattern (dimensions in mm)

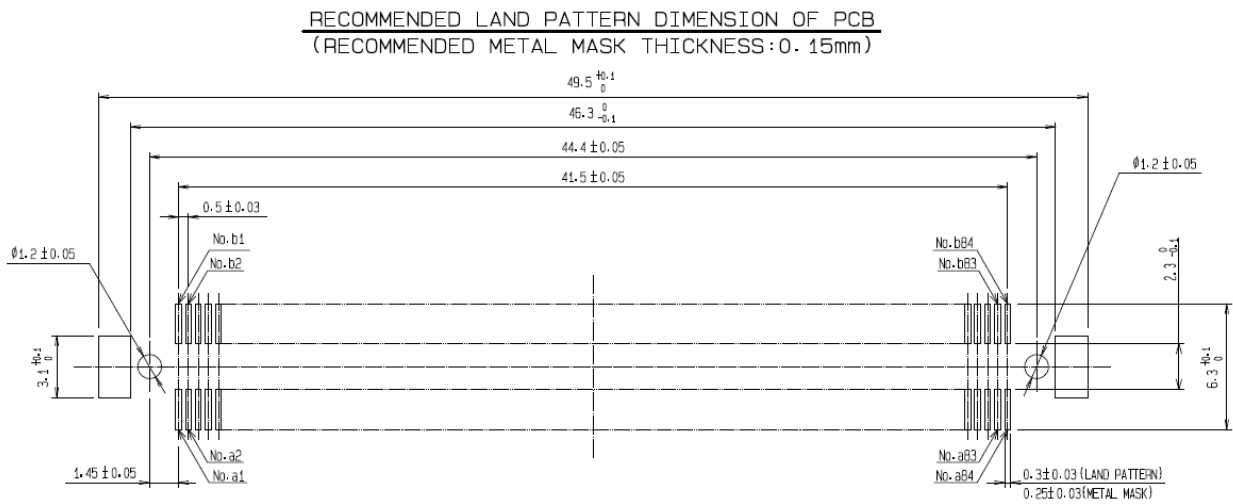

Figure 4 FX10 header land pattern (dimensions in mm)

The FX10 connector with 168 contacts does not have dedicated ground pins. This allows the PCB designer to assign signal and ground pins however they like. For high-speed differential interfaces referenced to 100Ω, a GSGSG pin assignment is required for optimal impedance matching within the connector. It is also recommended to stagger the signal pins from one row to the next in order to reduce crosstalk between rows within the connector. This pin assignment is shown in Figure 5.

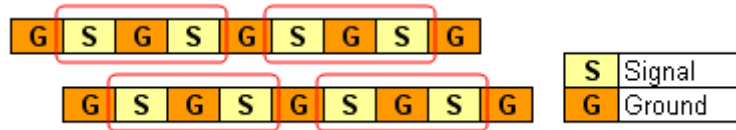

Figure 5 Recommended pin assignment for high speed 100Ω differential pairs

2.2 Ground plane with and without cutouts

In many cases, the impedance controlled PCB traces will be narrower than the FX10 connector pads. If the 100Ω differential traces are 0.165mm wide while the connector pads are 0.3mm wide, the impedance of the pads will be lower than 100Ω. Cutouts in the plane directly beneath the signal pads would eliminate this impedance mismatch. Figure 6 shows an example of cutouts that yield a good 100Ω differential impedance with the PCB stackup shown in Figure 7.

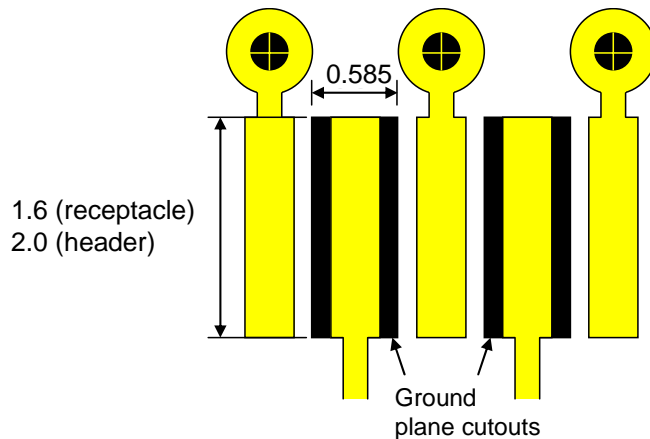

Figure 6 Example of cutouts in ground plane underneath FX10 footprint for impedance matching (dimensions in mm)

Cu Layer	Cu Thick. (mils)	Cu Foil wt (oz)	DK	Lam. Thick. (mils)	Description
1	2.00	0.5 oz			Foil, 0.5 oz
2	0.60	0.5 oz	4.00	3.75	Prepreg FR406 2113(57) 18x24G
3	0.60	0.5 oz	4.00	5.00	Core FR406 5mils 1-1652 0.5 oz / 0.5 oz 18x24G
			4.00	3.45	Prepreg FR406 2113(57) 18x24G
			4.00	31.00	Core FR406 31mils 4-7628 1-1080 0.5 oz / 0.5 oz 18x24G
			4.00	3.45	Prepreg FR406 2113(57) 18x24G
4	0.60	0.5 oz	4.00	5.00	Core FR406 5mils 1-1652 0.5 oz / 0.5 oz 18x24G
5	0.60	0.5 oz	4.00	5.00	Core FR406 5mils 1-1652 0.5 oz / 0.5 oz 18x24G
6	2.00	0.5 oz	4.00	3.75	Prepreg FR406 2113(57) 18x24G
					Foil, 0.5 oz

Figure 7 Example PCB stackup

However, in order to compensate for the high impedance at the pins of the FX10 connector, using ground plane with no cutouts is recommended. Without ground cutouts, the low impedance at the signal pads will balance with the high impedance section of the vertical pins of the FX10, giving 100Ω overall differential impedance for the connector and via model.

2.3 Recommended ground via locations

When grounding pins on the PCB, it is best to place the ground vias as close to the connector pads as possible. This will help ensure a good return path for the high-speed signals. Figure 8 shows some example ground vias.

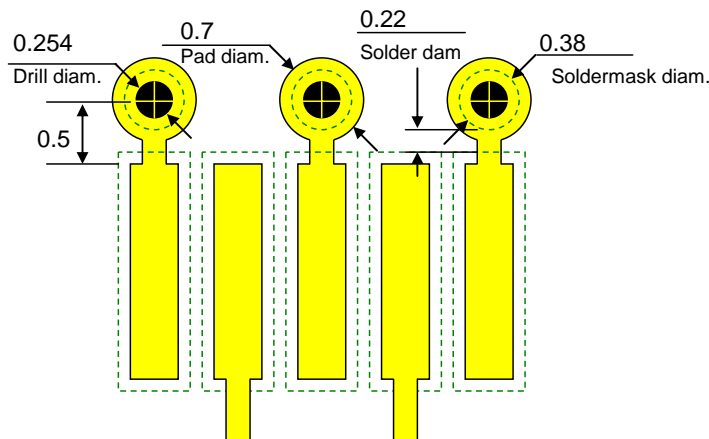

Figure 8 Example vias for grounding FX10 pins on PCB (dimensions in mm)

2.4 Routing suggestions / examples

Since FX10 is a dual row surface mount connector, traces can be routed on the surface layer directly out of the connector footprint. Differential pairs can be routed differentially with some coupling between the traces, as shown in Figure 9. Differential pairs can also be routed as uncoupled 50Ω traces, as shown in Figure 10. The advantage of routing them this way is that the traces can be routed straight out to vias with a 1mm pitch since the signal pad to signal pad pitch is also 1mm. This eliminates the discontinuities introduced by the varying trace pitch when routing in and out of connector pads and vias.

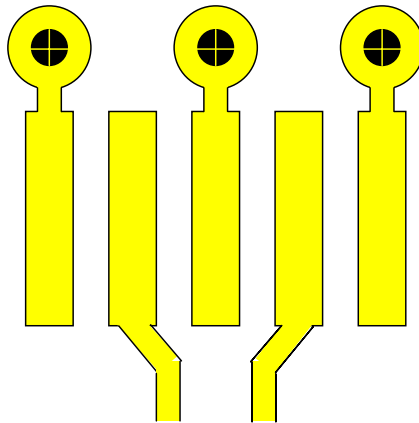

Figure 9 Routing differential traces from the FX10 footprint

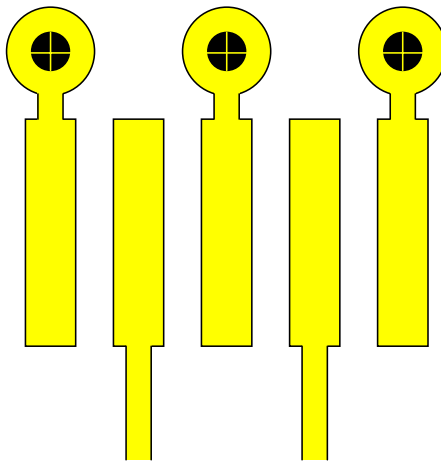

Figure 10 Routing a differential pair using uncoupled 50Ω traces from the FX10 footprint

Traces can also be routed on inner layers by placing signal vias close to the FX10 footprint. Examples of differential vias and their dimensions are shown in Figure 11 for the model with ground cutout, and Figure 14 for the model without ground cutout. These vias were simulated and optimized using the 3D field solver HFSS.

For the case with ground cutout, the FX10 header footprint and PCB stackup of Figure 7 were used. Inner layer traces were routed on layer 4 to keep the stub length short. Simulation results are shown in Figure 12 and Figure 13.

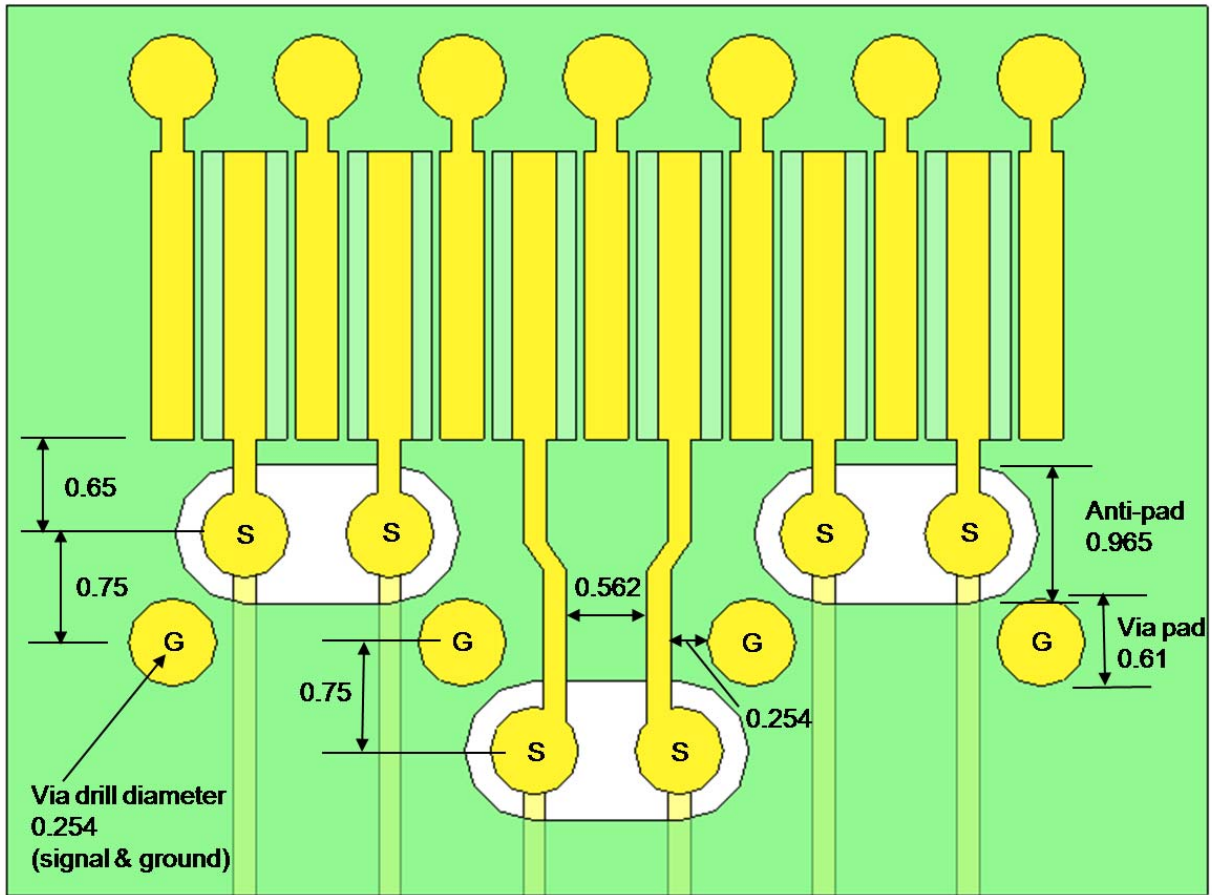

Figure 11 Example of differential vias for routing from top layer to inner layer (dimensions in mm)

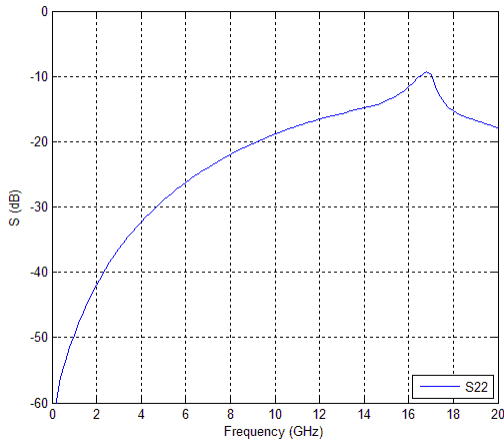

Figure 12 Differential return loss of differential vias

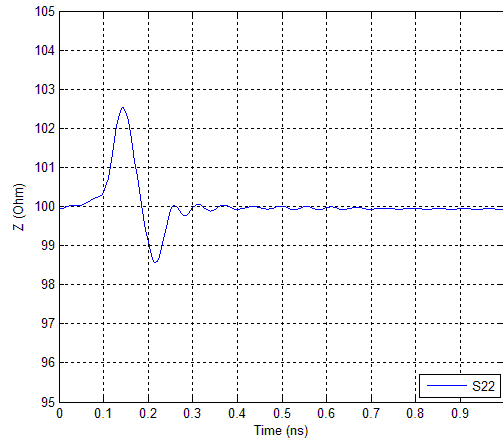

Figure 13 Differential TDR @50ps (20-80%) rise time of differential vias

The optimized recommended via footprint model without ground cutout is shown in Figure 14, with its stackup shown in Figure 15. In this model, pairs 1, 2 and 3 were routed through the lower layer 6, and pairs 4 and 5 were routed through layer 3. Simulation results for return loss, impedance profile and cross-talk are shown in Figure 16, Figure 17, Figure 18 and Figure 19.

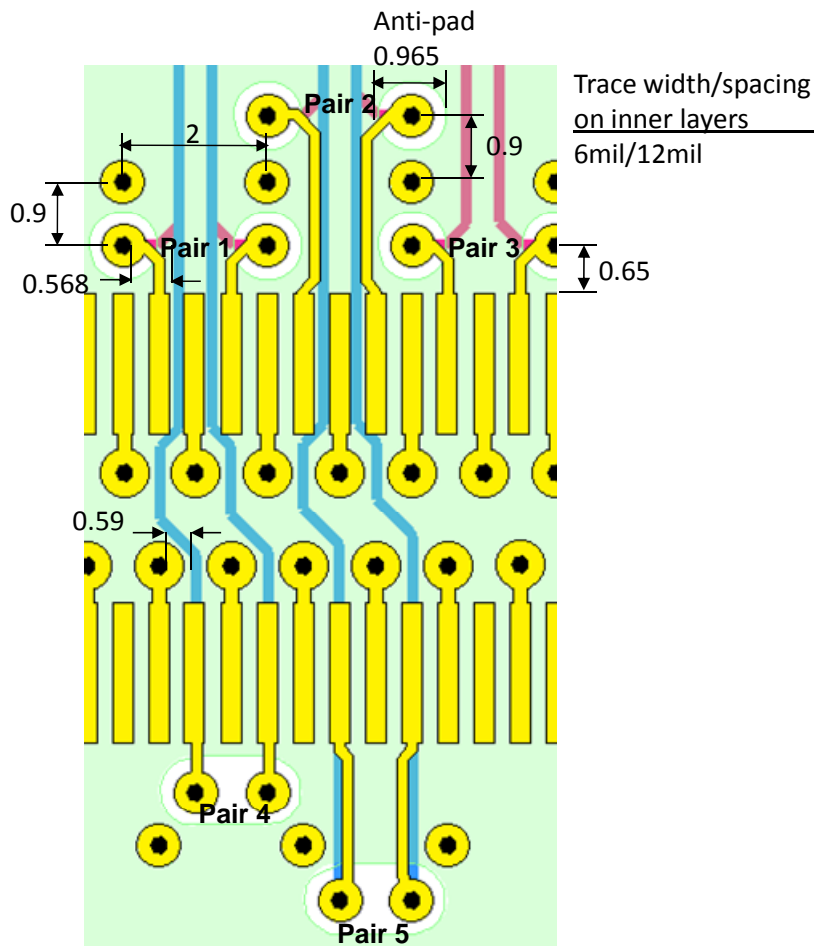

Figure 14 Example of routing on inner layers underneath FX10 connector (dimensions in mm)

Layer	Cu Thick. (mils)	Cu Foil wt (oz)	DK	Lam. Thick. (mils)
1	2.00	0.5 oz	4.00	3.75
2	0.60	0.5 oz	4.00	5.00
3	0.60	0.5 oz	4.00	12.30
4	0.60	0.5 oz	4.00	12.00
5	0.60	0.5 oz	4.00	12.30
6	0.60	0.5 oz	4.00	5.00
7	0.60	0.5 oz	4.00	3.75
8	2.00	0.5 oz	4.00	3.75

Figure 15 Example PCB stackup with ground planes shielding inner signal layers

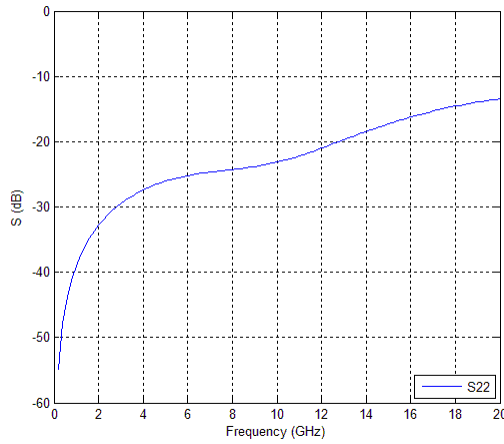

Figure 16 Differential return loss of differential vias

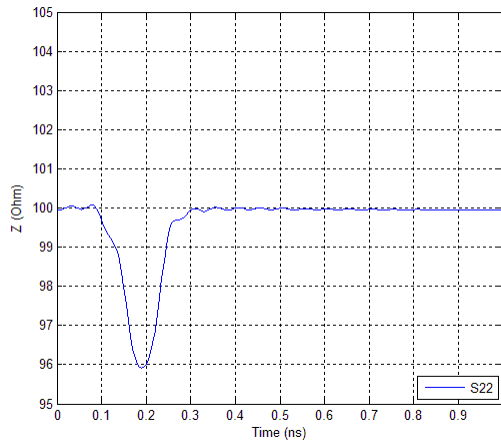

Figure 17 Differential TDR @50ps (20-80%) rise time of differential vias

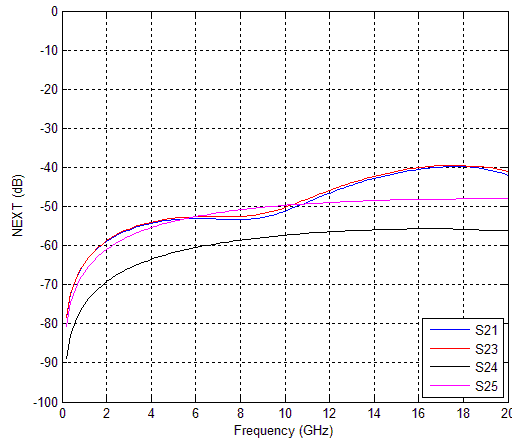

Figure 18 Differential NEXT for pair 2

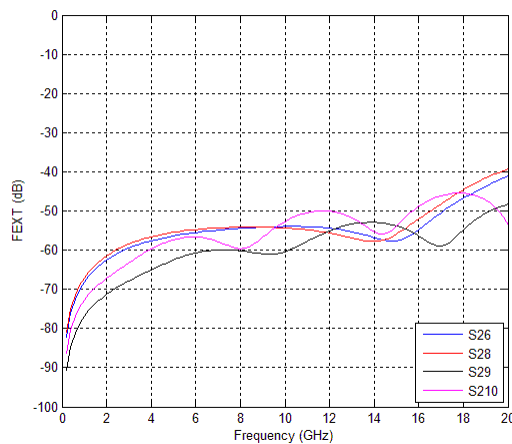

Figure 19 Differential FEXT for pair 2

3. Current rating

The FX10 connector can carry the current shown in the Table 1. Figure 20 shows the current rating per pin on the FX10 receptacle footprint. The current rating is determined by the temperature rise test, which conforms to EIA-364-70A.

No.	Pin No.	Current capacity
1	a1 to a8 , a77 to a84 b1 to b8 , b77 to b84 (32 pins in total)	0.75 A / Pin
2	a 9 to a76 b 9 to b76	0.3 A / Pin

Table 1 FX10 current rating per pin

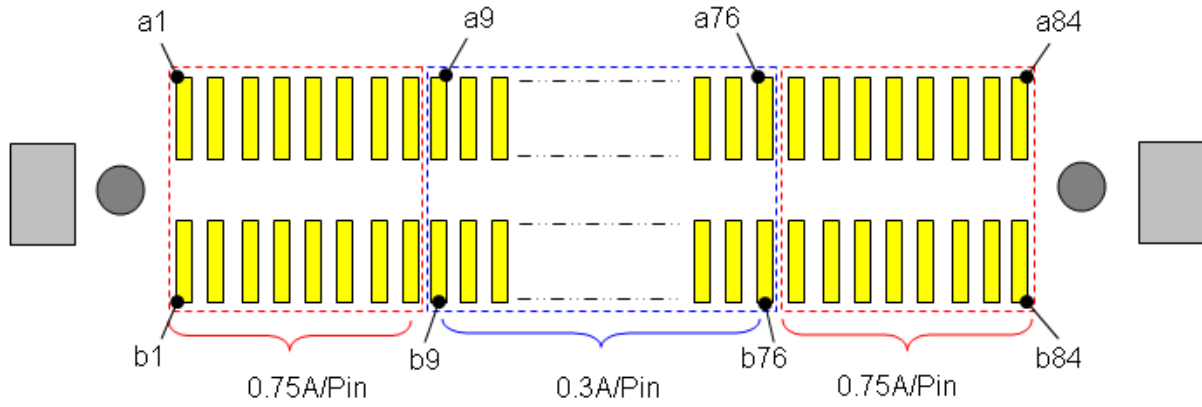

Figure 20 FX10 current rating per pin on FX10 Receptacle footprint