

APPLICABLE STANDARD							
RATING	OPERATING TEMPERATURE RANGE	-55 °C TO 85 °C ⁽¹⁾		STORAGE TEMPERATURE RANGE	-40 °C TO 60 °C ⁽²⁾		
	VOLTAGE	50 V AC		OPERATING HUMIDITY RANGE	RELATIVE HUMIDITY 95 % RH MAX. ⁽³⁾		
	CURRENT	0.75A	No.a1~a8,a77~a84 No.b1~b8,b77~b84		STORAGE HUMIDITY RANGE	40 % TO 70 % ⁽²⁾	
0.3A		No.a9~a76,b9~b76					
SPECIFICATIONS							
ITEM		TEST METHOD		REQUIREMENTS		QT	AT
CONSTRUCTION							
GENERAL EXAMINATION		VISUAL AND WITH MEASURING INSTRUMENT		ACCORDING TO A DRAWING		X	X
MARKING		CONFIRM VISUALLY				X	X
ELECTRIC CHARACTERISTICS							
CONTACT RESISTANCE [EIA-364-23]		100 mA and 20 mV OPEN CIRCUIT MAX		60 mΩ MAX		X	—
INSULATION RESISTANCE [EIA-364-21]		100 V DC		100 MΩ MIN.		X	—
VOLTAGE PROOF [EIA-364-20]		150 V AC FOR 1 MINUTE		NO FLASHOVER OR BREAKDOWN		X	X
MECHANICAL CHARACTERISTICS							
INSERTION AND WITHDRAWAL FORCES [EIA-364-13]		MEASURED BY APPLICABLE CONNECTORS		INSERTION FORCE: 100.8 N MAX WITHDRAWAL FORCE: 4.2 N MIN		X	—
MECHANICAL OPERATION [EIA-364-09]		50 TIMES INSERTION AND EXTRACTION		1) CONTACT RESISTANCE CHANGE: 10 mΩ OR LESS 2) NO DAMAGE, CRACK OR LOOSENESS OF PARTS		X	—
RANDOM VIBRATION [EIA-364-28]		FREQUENCY: 20 TO 500 Hz POWER SPECTRAL DENSITY: 0.02 G ² /Hz OVERALL rms G: 3.1 Grms FOR 15 MINUTES IN THREE DIRECTIONS		1) NO ELECTRICAL DISCONTINUITY OF 1μs OR MORE 2) NO DAMAGE, CRACK OR LOOSENESS OF PARTS		X	—
SHOCK [EIA-364-27]		490 m/s ² , DURATION OF PULSE: 11 ms 3 EACH DIRECTION, 3 AXIS				X	—
ENVIRONMENTAL CHARACTERISTICS							
THERMAL SHOCK [EIA-364-32]		TEMPERATURE: -55 → 15 ~ 35 → 85 → 15 ~ 35 °C TIME: 30 → 5 → 30 → 5 min. UNDER 10 CYCLES		1) CONTACT RESISTANCE CHANGE: 10 mΩ OR LESS 2) NO DAMAGE, CRACK OR LOOSENESS OF PARTS		X	—
CYCLIC TEMPERATURE AND HUMIDITY [EIA-364-31]		@ 25 °C, 80% RH: 60 MIN DWELL TIME 30 MIN RAMP TIME @ 65 °C, 50% RH: 60 MIN DWELL TIME UNDER 24 CYCLES				X	—
DRY HEAT [EIA-364-17]		EXPOSED AT 105 °C, 1000 hr				X	—
MIXED FLOWING GAS [EIA-364-65]		EXPOSED AT 30 °C, 70% Cl ₂ : 10 ppb, NO ₂ : 200 ppb, H ₂ S : 10 ppb, SO ₂ : 100 ppb UNMATED 7 DAYS, MATED 7 DAYS		1) CONTACT RESISTANCE CHANGE: 10 mΩ OR LESS 2) NO HEAVY CORROSION		X	—
RESISTANCE TO SOLDERING HEAT		1) REFLOW SOLDERING : 250 °C MAX, : 220 °C MIN, FOR 60 s 2) SOLDERING IRONS : 360 °C, FOR 5 s		NO DEFORMATION OF CASE OF EXCESSIVE LOOSENESS OF THE TERMINAL.		X	—
SOLDERABILITY		SOLDERED AT SOLDER TEMPERATURE, 240°C, FOR IMMERSION DURATION, 3 s.		A NEW UNIFORM COATING OF SOLDER SHALL OVER A MINIMUM OF 95 % OF THE SURFACE BEING IMMERSSED.		X	—
	COUNT	DESCRIPTION OF REVISIONS		DESIGNED	CHECKED	DATE	
REMARK				APPROVED	HS. OKAWA	10.09.03	
				CHECKED	HT. YAMAGUCHI	10.09.03	
				DESIGNED	AH. EDASHIGE	10.09.03	
				DRAWN	HK. SUNADORI	10.09.03	
NOTE -- QT: QUALIFICATION TEST; AT: ASSURANCE TEST; X: APPLICATION TEST				DRAWING NO.		TELC4-210580	
HRS	SPECIFICATION SHEET			PART NO.	FX10B-168S-SV (83)		
	HIROSE ELECTRIC CO., LTD.			CODE NO.	CL570		1/1

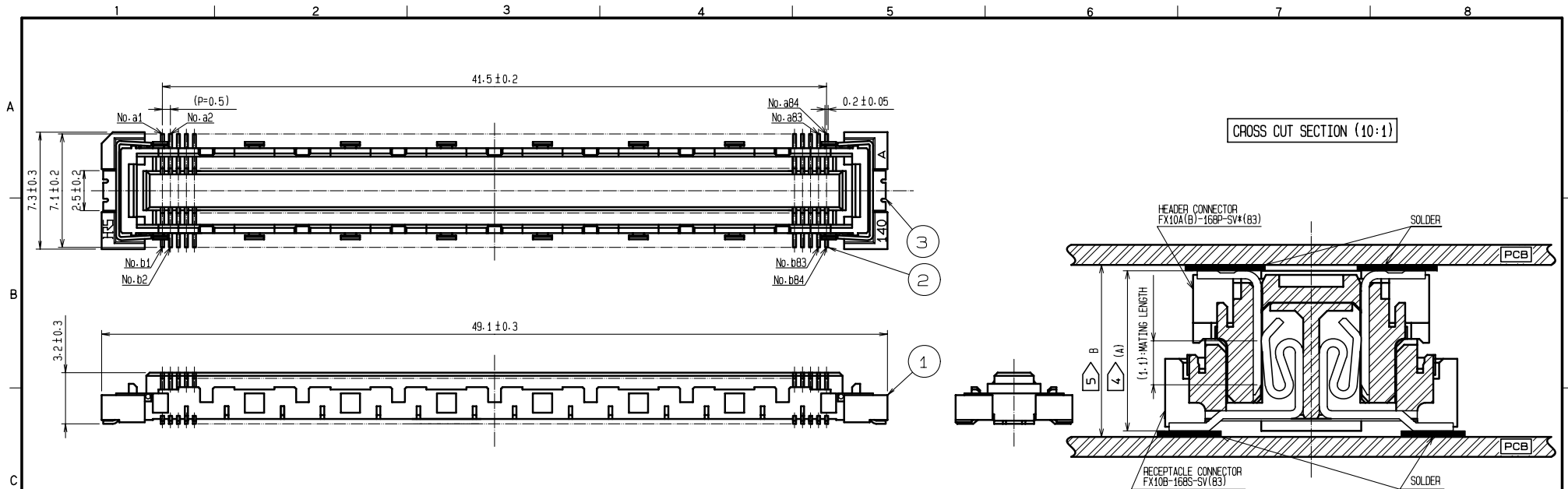

RECOMMENDED LAND PATTERN DIMENSION OF PCB
(RECOMMENDED METAL MASK THICKNESS: 0.15mm)

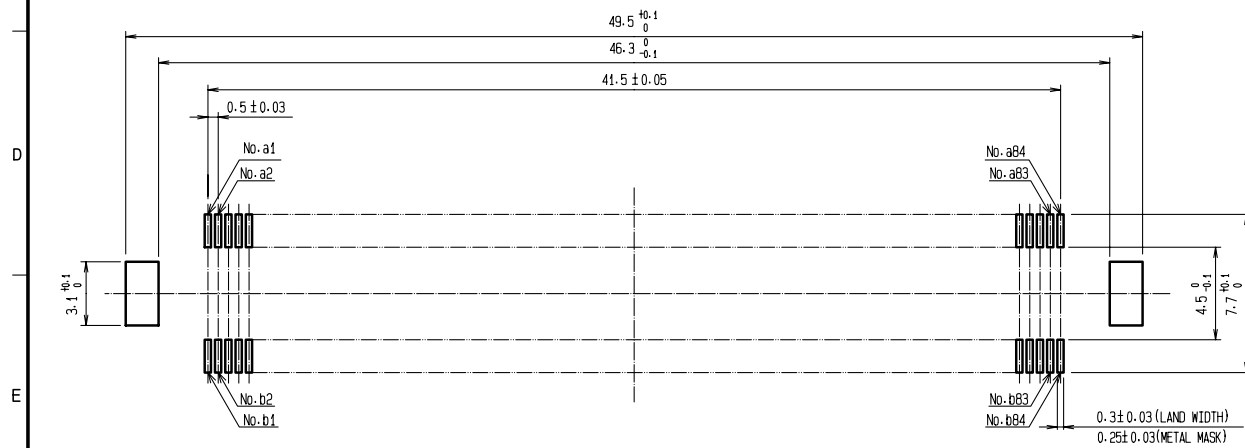

STACKING HEIGHT

	FX10B-168S-SV(83)	
	4 > (A)	5 > B
FX10A(B)-168P-SV(83)	4	4.3 ± 0.127
FX10A(B)-168P-SV1(83)	5	5.3 ± 0.127
FX10A(B)-168P-SV2(83)	6	6.0 ± 0.127
FX10A(B)-168P-SV3(83)	7	7.0 ± 0.127
FX10A(B)-168P-SV4(83)	8	8.0 ± 0.127

- NOTES
- 1 SMT LEAD-COPLANARITY: 0.1 MAX.
 - 2 THIS PRODUCT HAS NO POLARITY TO PATTERN FOR MOUNTING.
 - 3 THE DIMENSIONS IN PARENTHESES ARE FOR REFERENCE.
 - 4 > STACKING HEIGHT FROM LEAD TO LEAD. (REFERENCE DIMENSIONS)
 - 5 > BOARD DISTANCE.

2	PHOSPHOR BRONZE	CONTACT AREA: GOLD 0.76µm min.	5	PET	TOP COVER TAPE			
		LEAD AREA: GOLD 0.03µm min.	4	PS	EMBOSSD CARRIER TAPE			
		UNDER PLATING: NICKEL 1.3µm min.	3	PHOSPHOR BRONZE	SURFACE AREA: GOLD 0.03µm min.			
1	LCP	BEIGE UL94V-0			UNDER PLATING: NICKEL 1.3µm min.			
NO.	MATERIAL	FINISH . REMARKS	NO.	MATERIAL	FINISH . REMARKS			
UNITS mm	④	SCALE 4 : 1	△	COUNT	DESCRIPTION OF REVISIONS	DESIGNED	CHECKED	DATE
APPROVED : HS. OKAWA		10.09.03		DRAWING NO.		TEDC3-210580		
CHECKED : HT. YAMAGUCHI		10.09.03		PART NO.		FX10B-168S-SV(83)		
DESIGNED : AH. EDASHIGE		10.09.03		CODE NO.		CL570		
DRAWN : HK. SUNADORI		10.09.03						

DRAWING FOR PACKING(2:1)

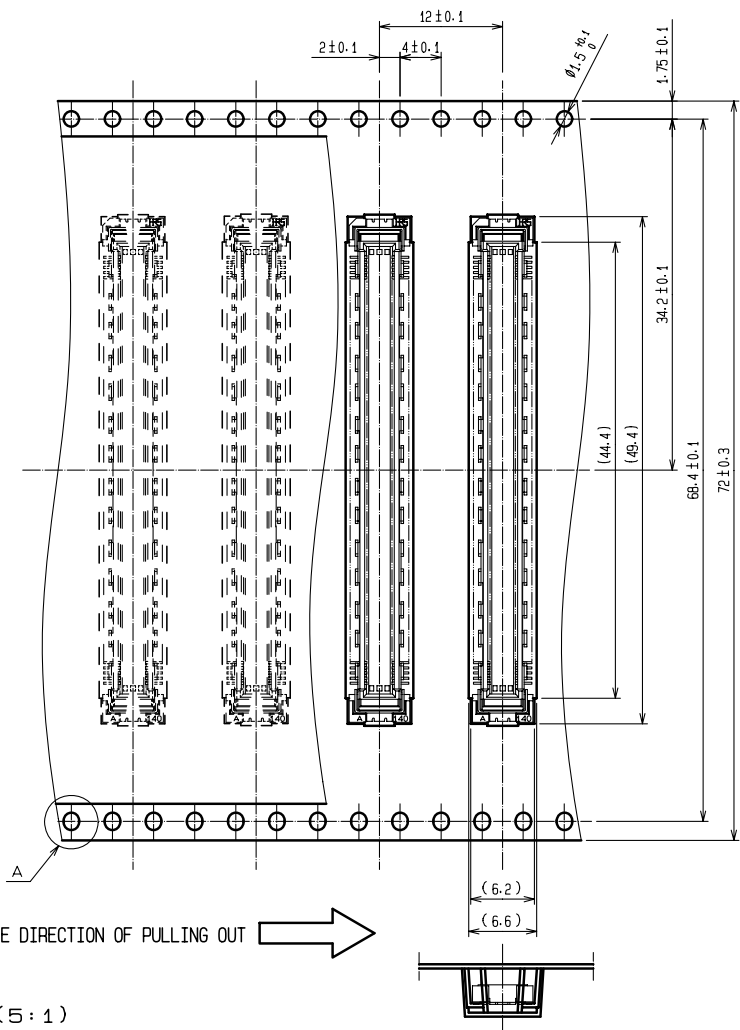

A (5:1)

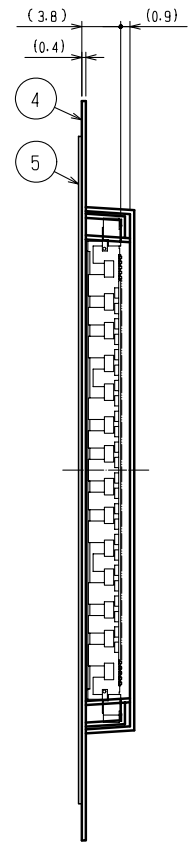
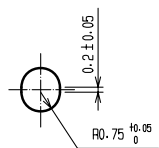

REELED DIMENSION(Free)

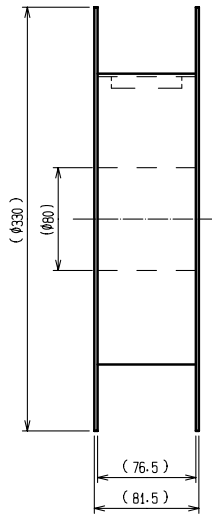
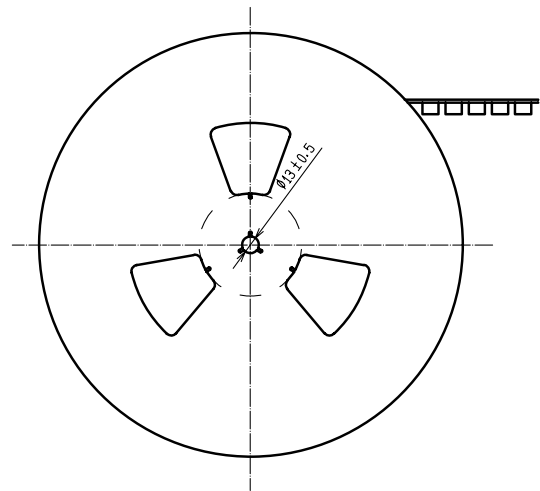

- NOTES 1 1REEL : 1000 CONNECTORS.
- 2 MINIMUM 10 COMPARTMENTS FROM BOTH REEL ENDS REMAIN EMPTY.
- 3 THIS PRODUCT HAS NO POLARITY TO TAPE AND REEL PACKAGING.
- 4 THE DIMENSIONS IN PARENTHESSES ARE FOR REFERENCE.

HRS	DRAWING NO.	TEDC3-210580
	PART NO.	FX10B-168S-SV(83)
	CODE NO.	CL570
		△ 2/2