

APPLICABLE STANDARD							
RATING	OPERATING TEMPERATURE RANGE	<b>-55 °C TO 85 °C<sup>(1)</sup></b>		STORAGE TEMPERATURE RANGE	<b>-10 °C TO 60 °C<sup>(2)</sup></b>		
	VOLTAGE	<b>50 V AC</b>		OPERATING HUMIDITY RANGE	<b>RELATIVE HUMIDITY 95 % RH MAX.<sup>(3)</sup></b>		
	CURRENT	0.75A	No.a1~a8,a77~a84 No.b1~b8,b77~b84	STORAGE HUMIDITY RANGE	<b>40 % TO 70 %<sup>(2)</sup></b>		
		0.3A	No.a9~a76,b9~b76				
SPECIFICATIONS							
ITEM	TEST METHOD			REQUIREMENTS		QT	AT
<b>CONSTRUCTION</b>							
GENERAL EXAMINATION	VISUALLY AND BY MEASURING INSTRUMENT.			ACCORDING TO DRAWING.		x	x
MARKING	CONFIRMED VISUALLY.					x	x
<b>ELECTRIC CHARACTERISTICS</b>							
CONTACT RESISTANCE	100 mA (DC OR 1000 Hz).			60 mΩ MAX.		x	-
INSULATION RESISTANCE	100 V DC			100 MΩ MIN.		x	-
VOLTAGE PROOF	150 V AC FOR 1 min.			NO FLASHOVER OR BREAKDOWN.		x	x
<b>MECHANICAL CHARACTERISTICS</b>							
INSERTION AND WITHDRAWAL FORCE	MEASURED BY APPLICABLE CONNECTOR.			INSERTION FORCE: 100.8 N MAX. WITHDRAWAL FORCE: 4.2 N MIN.		x	-
MECHANICAL OPERATION	50 TIMES INSERTIONS AND EXTRACTIONS.			① CONTACT RESISTANCE: 70 mΩ MAX. ② NO DAMAGE, CRACK AND LOOSENESS OF PARTS.		x	-
VIBRATION	FREQUENCY 10 TO 55 Hz, SINGLE AMPLITUDE : 0.75 mm, AT 10 CYCLES FOR 3 DIRECTIONS.			① NO ELECTRICAL DISCONTINUITY OF 1 μs. ② NO DAMAGE, CRACK AND LOOSENESS OF PARTS.		x	-
SHOCK	490 m/s <sup>2</sup> , DURATION OF PULSE 11 ms AT 3 TIMES FOR 3 DIRECTIONS.					x	-
<b>ENVIRONMENTAL CHARACTERISTICS</b>							
DAMP HEAT (STEADY STATE)	EXPOSED AT 40±2 °C, 90 ~ 95 %, 96 h.			① CONTACT RESISTANCE: 70 mΩ MAX. ② INSULATION RESISTANCE: 100 MΩ MIN.		x	-
RAPID CHANGE OF TEMPERATURE	TEMPERATURE -55 → +15 ~ +35 → +85 → +15 ~ +35 °C TIME 30 → 2 ~ 3 → 30 → 2 ~ 3 min. UNDER 5 CYCLES.			③ NO DAMAGE, CRACK AND LOOSENESS OF PARTS.		x	-
DRY HEAT	EXPOSED AT 85 °C, 96h.			① CONTACT RESISTANCE: 70 mΩ MAX.		x	-
COLD	EXPOSED AT -55 °C, 96h.			② NO DAMAGE, CRACK AND LOOSENESS OF PARTS.		x	-
CORROSION SALT MIST	EXPOSED IN 5 % SALT WATER SPRAY FOR 48 h.			① CONTACT RESISTANCE: 70 mΩ MAX. ② NO HEAVY CORROSION.		x	-
SULPHUR DIOXIDE	EXPOSED IN 10 PPM FOR 96 h. (TEST STANDARD: JIS C 0090)					x	-
RESISTANCE TO SOLDERING HEAT	1) REFLOW SOLDERING : 250 °C MAX, : 220 °C MIN, FOR 60 s 2) SOLDERING IRONS : 360 °C, FOR 5 s			NO DEFORMATION OF CASE OF EXCESSIVE LOOSENESS OF THE TERMINAL.		x	-
SOLDERABILITY	SOLDERED AT SOLDER TEMPERATURE, 240°C, FOR IMMERSION DURATION, 3 s.			A NEW UNIFORM COATING OF SOLDER SHALL COVER A MINIMUM OF 95 % OF THE SURFACE BEING IMMERSSED.		x	-
	COUNT	DESCRIPTION OF REVISIONS		DESIGNED	CHECKED	DATE	
REMARK <sup>(1)</sup> TEMPERATURE RISE INCLUDED WHEN ENERGIZED. <sup>(2)</sup> THIS STORAGE INDICATES A LONG-TERM STORAGE STATE FOR THE UNUSED PRODUCT BEFORE THE BOARD MOUNTED. <sup>(3)</sup> NO DEW CONDENSATION IS PERMITTED. Unless otherwise specified, refer to JIS C 5402.				APPROVED	HS. OKAWA	09. 12. 24	
				CHECKED	HT. YAMAGUCHI	09. 12. 24	
				DESIGNED	TP. MATSUMOTO	09. 12. 24	
				DRAWN	HK. SUNADORI	09. 12. 24	
Note QT:Qualification Test AT:Assurance Test X:Applicable Test				DRAWING NO.		TELC4-210542	
	SPECIFICATION SHEET			PART NO.	FX10A-168P-SV4 (83)		
	HIROSE ELECTRIC CO., LTD.			CODE NO.	CL570		1/1

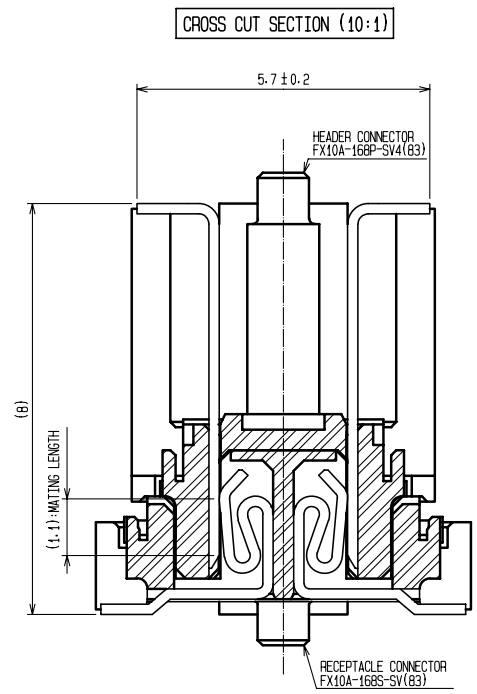

RECOMMENDED LAND PATTERN DIMENSION OF PCB  
(RECOMMENDED METAL MASK THICKNESS: 0.15mm)

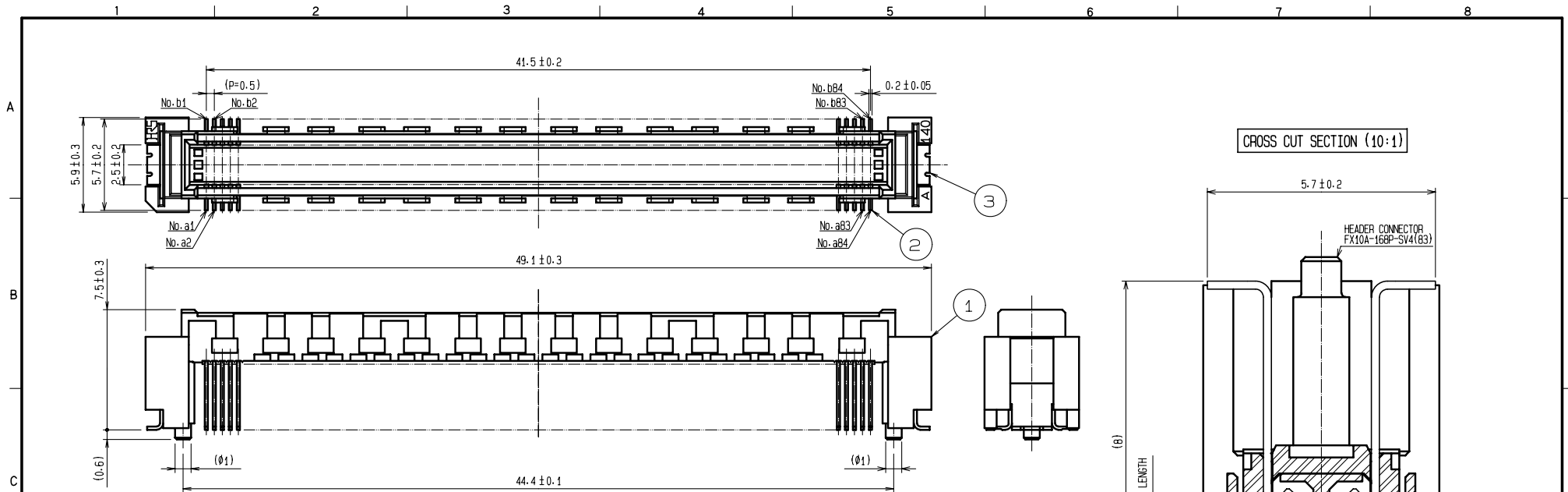
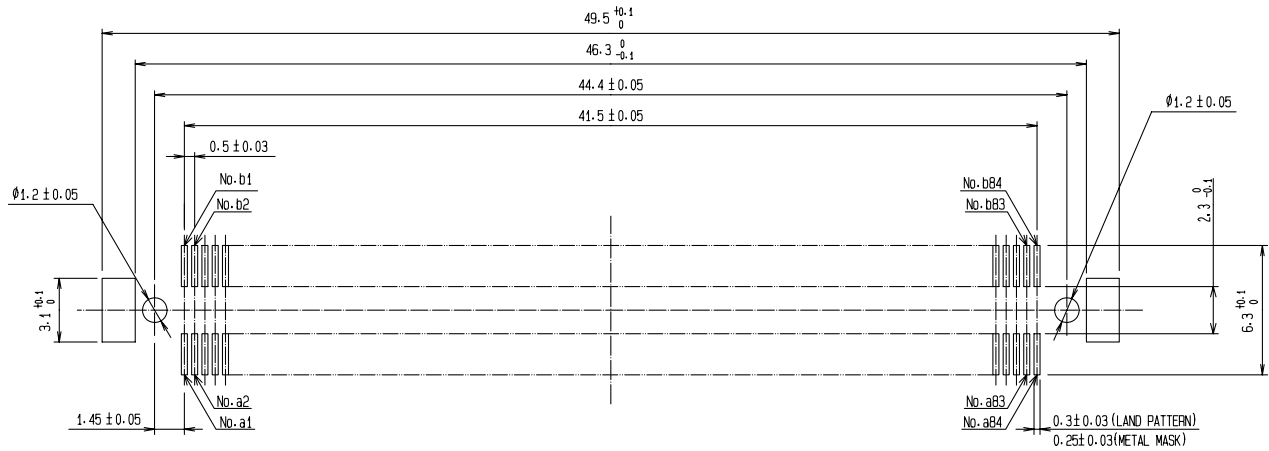

PRELIMINARY DRAWING

- NOTES
- 1 SMT LEAD-COPLANARITY: 0.1 MAX.
  - 2 THIS PRODUCT HAS NO POLARITY TO PATTERN FOR MOUNTING.
  - 3 THE DIMENSIONS IN PARENTHESES ARE FOR REFERENCE.

2	PHOSPHOR BRONZE	CONTACT AREA: GOLD 0.76μm min.	5	PET	TOP COVER TAPE		
		LEAD AREA: GOLD 0.03μm min.	4	PS	EMBOSSSED CARRIER TAPE		
		UNDER PLATING: NICKEL 1.3μm min.	3	PHOSPHOR BRONZE	SURFACE AREA: GOLD 0.03μm min.		
1	LCP	BEIGE UL94V-0			UNDER PLATING: NICKEL 1μm min.		
NO.	MATERIAL	FINISH . REMARKS	NO.	MATERIAL	FINISH . REMARKS		
UNITS mm	⊕	SCALE 4 : 1	COUNT △	DESCRIPTION OF REVISIONS	DESIGNED	CHECKED	DATE
APPROVED : HS. OKAWA		10.01.26	DRAWING NO.		TEDC3-210542		
CHECKED : HT. YAMAGUCHI		10.01.26	PART NO.		FX10A-168P-SV4(B3)		
DESIGNED : AH. EDASHIGE		10.01.26	CODE NO.		CL570		
DRAWN : HK. SUNADORI		10.01.26					

# DRAWING FOR PACKING(2:1)

REELED DIMENSION(Free)

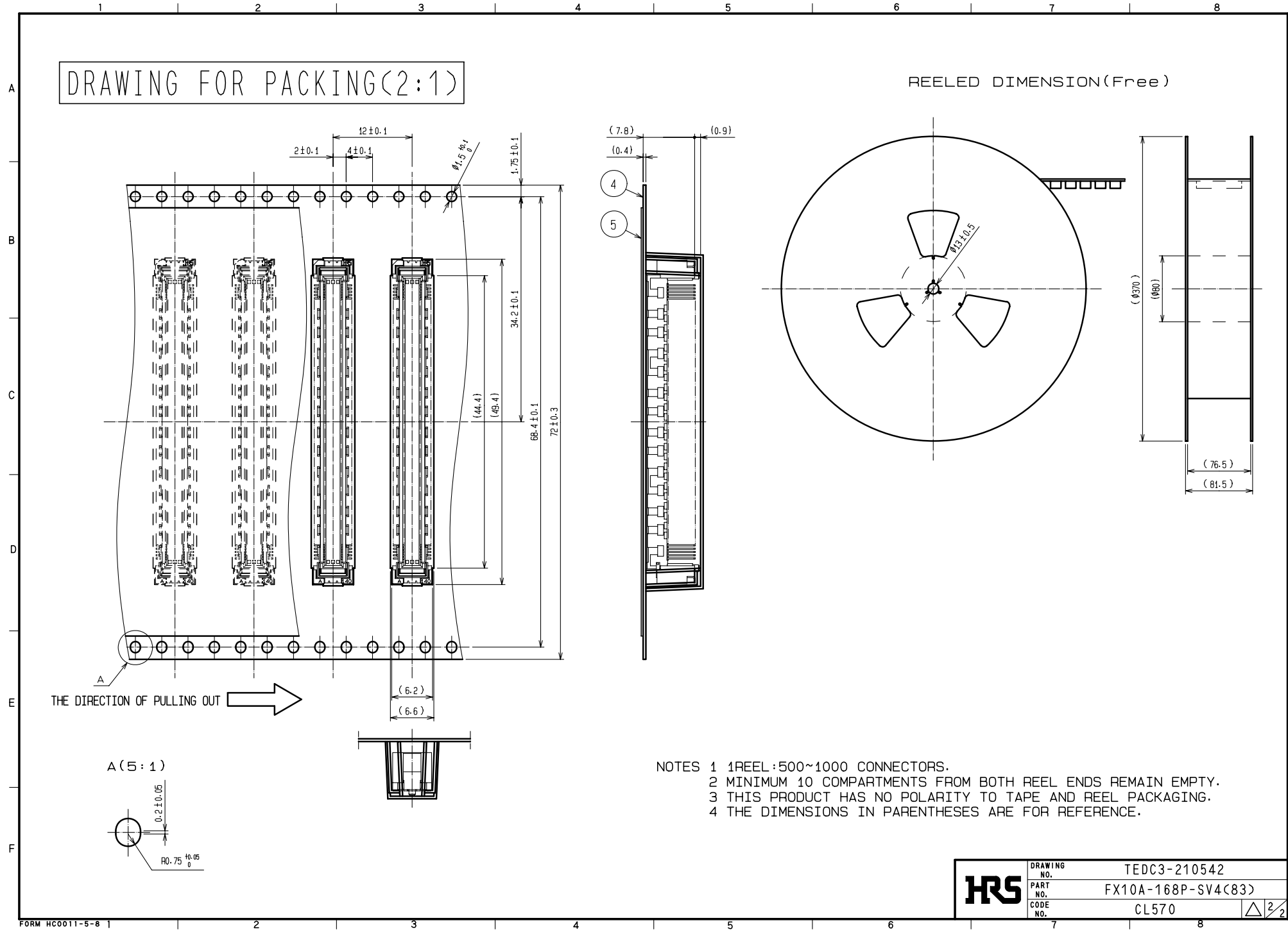

- NOTES
- 1 REEL : 500~1000 CONNECTORS.
  - 2 MINIMUM 10 COMPARTMENTS FROM BOTH REEL ENDS REMAIN EMPTY.
  - 3 THIS PRODUCT HAS NO POLARITY TO TAPE AND REEL PACKAGING.
  - 4 THE DIMENSIONS IN PARENTHESSES ARE FOR REFERENCE.

<b>HRS</b>	DRAWING NO.	TEDC3-210542	△ 2/2
	PART NO.	FX10A-168P-SV4(83)	
	CODE NO.	CL570	