

APPLICABLE STANDARD								
RATING	OPERATING TEMPERATURE RANGE	-55 °C TO 85 °C ⁽¹⁾		STORAGE TEMPERATURE RANGE	-10 °C TO 60 °C ⁽²⁾			
	VOLTAGE	50 V AC		OPERATING HUMIDITY RANGE	RELATIVE HUMIDITY 95 % RH MAX. ⁽³⁾			
	CURRENT	0.75A	No.a1~a8,a77~a84 No.b1~b8,b77~b84		STORAGE HUMIDITY RANGE	40 % TO 70 % ⁽²⁾		
		0.3A	No.a9~a76,b9~b76					
SPECIFICATIONS								
ITEM	TEST METHOD			REQUIREMENTS	QT	AT		
CONSTRUCTION								
GENERAL EXAMINATION	VISUALLY AND BY MEASURING INSTRUMENT.			ACCORDING TO DRAWING.	x	x		
MARKING	CONFIRMED VISUALLY.				x	x		
ELECTRIC CHARACTERISTICS								
CONTACT RESISTANCE	100 mA (DC OR 1000 Hz).			60 mΩ MAX.	x	-		
INSULATION RESISTANCE	100 V DC			100 MΩ MIN.	x	-		
VOLTAGE PROOF	150 V AC FOR 1 min.			NO FLASHOVER OR BREAKDOWN.	x	x		
MECHANICAL CHARACTERISTICS								
INSERTION AND WITHDRAWAL FORCE	MEASURED BY APPLICABLE CONNECTOR.			INSERTION FORCE: 100.8 N MAX. WITHDRAWAL FORCE: 4.2 N MIN.	x	-		
MECHANICAL OPERATION	50 TIMES INSERTIONS AND EXTRACTIONS.			① CONTACT RESISTANCE: 70 mΩ MAX. ② NO DAMAGE, CRACK AND LOOSENESS OF PARTS.	x	-		
VIBRATION	FREQUENCY 10 TO 55 Hz, SINGLE AMPLITUDE : 0.75 mm, AT 10 CYCLES FOR 3 DIRECTIONS.			① NO ELECTRICAL DISCONTINUITY OF 1 μs. ② NO DAMAGE, CRACK AND LOOSENESS OF PARTS.	x	-		
SHOCK	490 m/s ² , DURATION OF PULSE 11 ms AT 3 TIMES FOR 3 DIRECTIONS.				x	-		
ENVIRONMENTAL CHARACTERISTICS								
DAMP HEAT (STEADY STATE)	EXPOSED AT 40±2 °C, 90 ~ 95 %, 96 h.			① CONTACT RESISTANCE: 70 mΩ MAX. ② INSULATION RESISTANCE: 100 MΩ MIN.	x	-		
RAPID CHANGE OF TEMPERATURE	TEMPERATURE-55→+15~+35→+85→+15~+35°C TIME 30 → 2 ~ 3 → 30 → 2 ~ 3 min. UNDER 5 CYCLES.			③ NO DAMAGE, CRACK AND LOOSENESS OF PARTS.	x	-		
DRY HEAT	EXPOSED AT 85 °C, 96h.			① CONTACT RESISTANCE: 70 mΩ MAX.	x	-		
COLD	EXPOSED AT -55 °C, 96h.			② NO DAMAGE, CRACK AND LOOSENESS OF PARTS.	x	-		
CORROSION SALT MIST	EXPOSED IN 5 % SALT WATER SPRAY FOR 48 h.			① CONTACT RESISTANCE: 70 mΩ MAX. ② NO HEAVY CORROSION.	x	-		
SULPHUR DIOXIDE	EXPOSED IN 10 PPM FOR 96 h. (TEST STANDARD: JIS C 0090)				x	-		
RESISTANCE TO SOLDERING HEAT	1) REFLOW SOLDERING : 250 °C MAX, : 220 °C MIN, FOR 60 s 2) SOLDERING IRONS : 360 °C, FOR 5 s			NO DEFORMATION OF CASE OF EXCESSIVE LOOSENESS OF THE TERMINAL.	x	-		
SOLDERABILITY	SOLDERED AT SOLDER TEMPERATURE, 240°C, FOR IMMERSION DURATION, 3 s.			A NEW UNIFORM COATING OF SOLDER SHALL COVER A MINIMUM OF 95 % OF THE SURFACE BEING IMMERSSED.	x	-		
	COUNT	DESCRIPTION OF REVISIONS		DESIGNED	CHECKED	DATE		
△								
REMARK ⁽¹⁾ TEMPERATURE RISE INCLUDED WHEN ENERGIZED. ⁽²⁾ THIS STORAGE INDICATES A LONG-TERM STORAGE STATE FOR THE UNUSED PRODUCT BEFORE THE BOARD MOUNTED. ⁽³⁾ NO DEW CONDENSATION IS PERMITTED. Unless otherwise specified, refer to JIS C 5402.				APPROVED	HS. OKAWA	09. 12. 17		
				CHECKED	HT. YAMAGUCHI	09. 12. 17		
				DESIGNED	TP. MATSUMOTO	09. 12. 17		
				DRAWN	HK. SUNADORI	09. 12. 17		
Note QT:Qualification Test AT:Assurance Test X:Applicable Test				DRAWING NO.	TELC4-210538			
HRS	SPECIFICATION SHEET			PART NO.	FX10A-168P-SV (83)			
	HIROSE ELECTRIC CO., LTD.			CODE NO.	CL570	△	1/1	

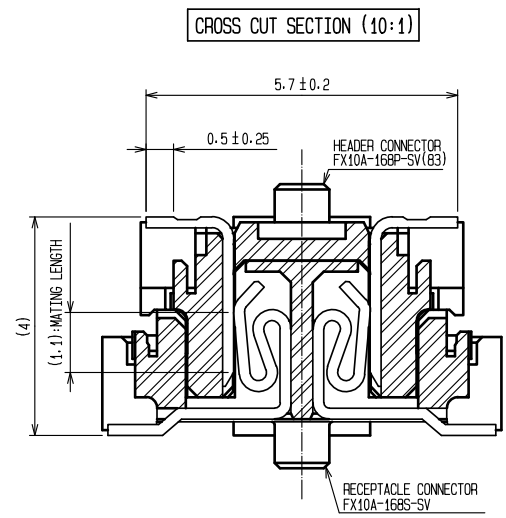

RECOMMENDED LAND PATTERN DIMENSION OF PCB
(RECOMMENDED METAL MASK THICKNESS: 0.15mm)

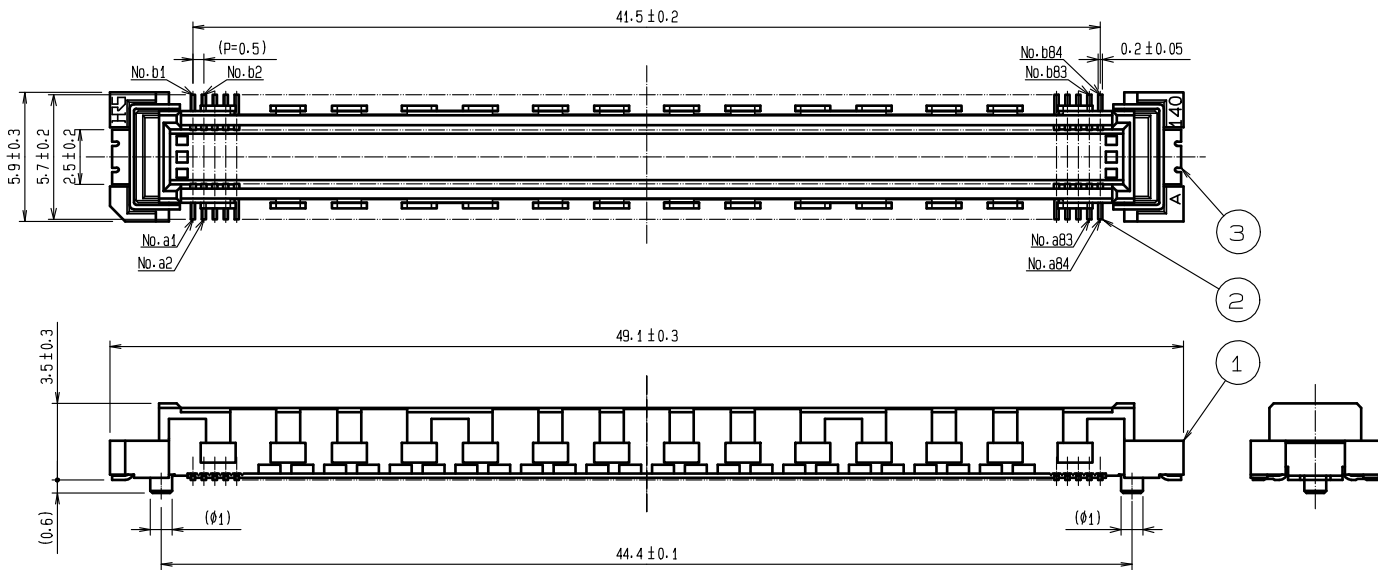
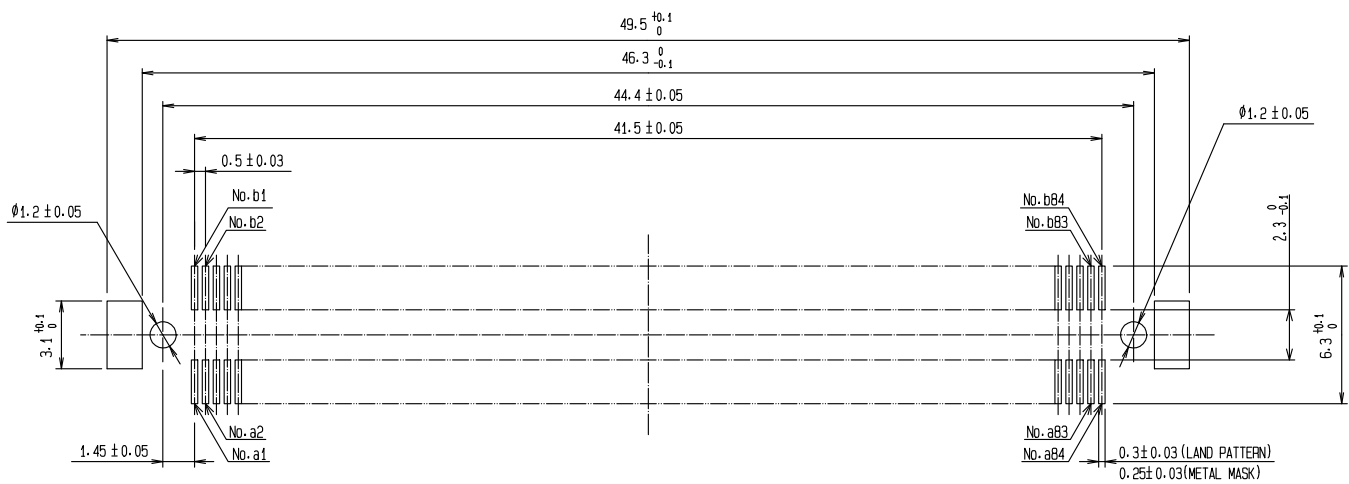

- NOTES
- 1 SMT LEAD-COPLANARITY: 0.1 MAX.
 - 2 THIS PRODUCT HAS NO POLARITY TO PATTERN FOR MOUNTING.
 - 3 THE DIMENSIONS IN PARENTHESES ARE FOR REFERENCE.

2	PHOSPHOR BRONZE	CONTACT AREA: GOLD 0.76µm min. LEAD AREA: TIN-PLATING 0.03µm min.	5 4	PET PS	TOP COVER TAPE EMBOSSED CARRIER TAPE		
1	LCP	UNDER PLATING: NICKEL 1.3µm min. BEIGE UL94V-0	3	PHOSPHOR BRONZE	SURFACE AREA: GOLD 0.03µm min. UNDER PLATING: NICKEL 1µm min.		
NO.	MATERIAL	FINISH . REMARKS	NO.	MATERIAL	FINISH . REMARKS		
UNITS		SCALE	COUNT	DESCRIPTION OF REVISIONS	DESIGNED	CHECKED	DATE
mm		4 : 1	△				
		APPROVED	DRAWING NO.		TEDC3-210538		
HIROSE ELECTRIC CO., LTD.		CHECKED	PART NO.		FX10A-168P-SV(83)		
		DESIGNED	CODE NO.		CL570		
		DRAWN					

DRAWING FOR PACKING(2:1)

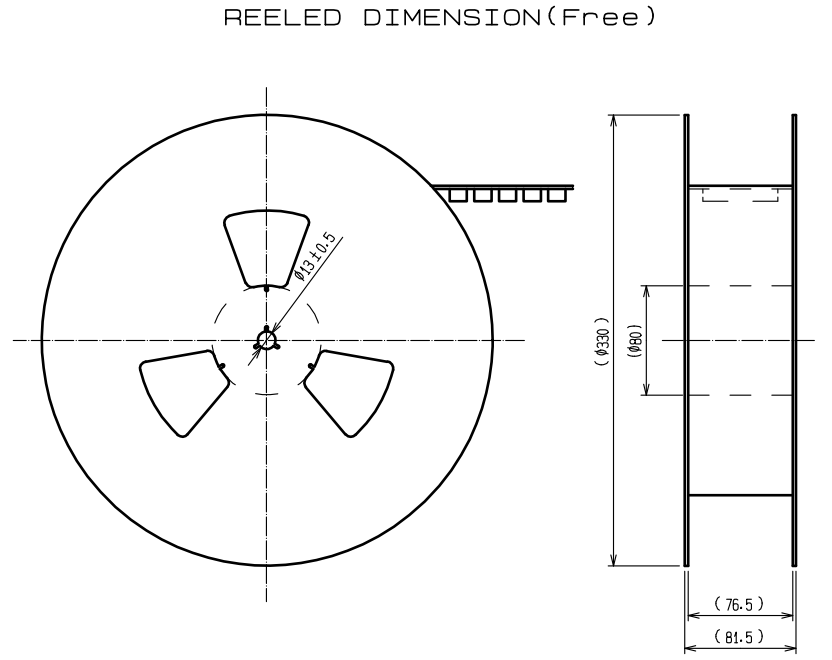
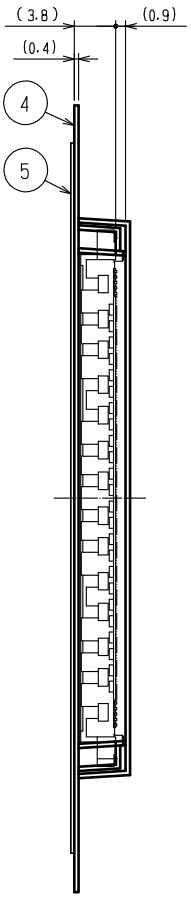
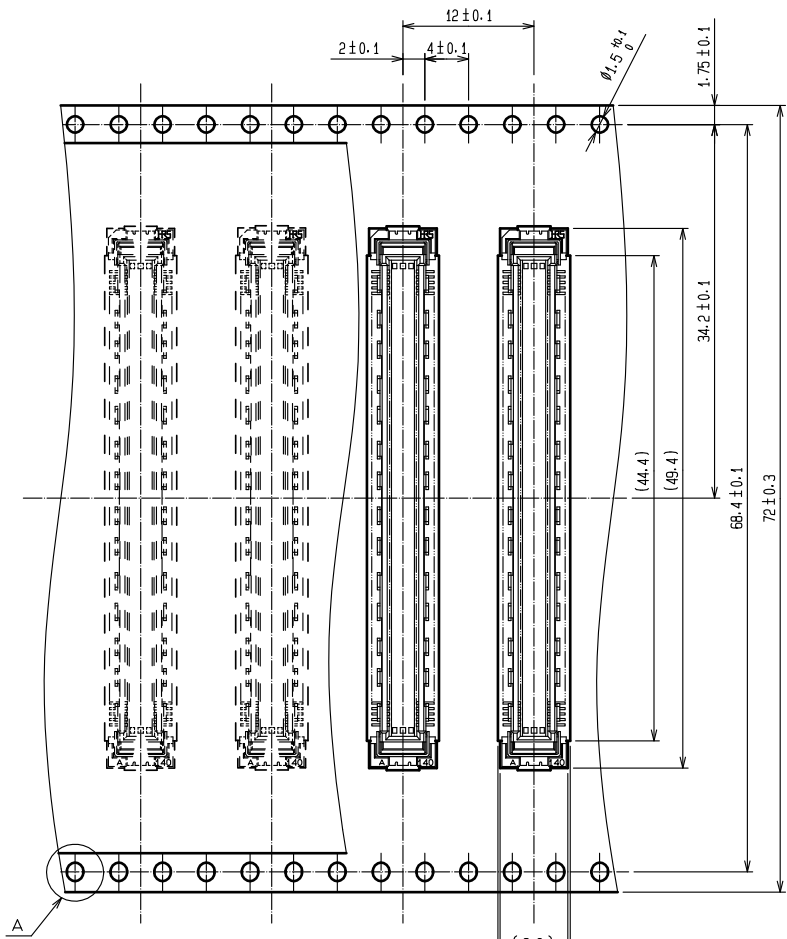

THE DIRECTION OF PULLING OUT

A (5:1)

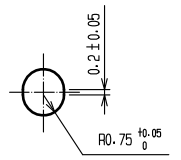

- NOTES
- 1 REEL:1000 CONNECTORS.
 - 2 MINIMUM 10 COMPARTMENTS FROM BOTH REEL ENDS REMAIN EMPTY.
 - 3 THIS PRODUCT HAS NO POLARITY TO TAPE AND REEL PACKAGING.
 - 4 THE DIMENSIONS IN PARENTHESES ARE FOR REFERENCE.

HRS	DRAWING NO.	TEDC3-210538		2/2
	PART NO.	FX10A-168P-SV(83)		
	CODE NO.	CL570		
	NO.			